

Uniclass JR12/JR23 L731	
Cl/SfB (52.7)	

ACO Water Management: Civils + Infrastructure



ACO Q-Ceptor

Bypass and full retention oil separators



Introduction to the ACO Group

Throughout the world ACO branded drainage and surface water management systems are recognised for their innovative design, high quality manufacture, environmental excellence and industry leading performance.

Today the ACO Group has a research and production base that reaches across four continents. This unmatched resource pioneers the development of solutions that are tailored to individual applications, meeting the need for high performance, sustainable products that deliver optimum value throughout their operational life.

ACO Technologies plc

ACO operates as ACO Technologies plc in the United Kingdom. Founded over 25 years ago, the company has grown quickly on a reputation for design innovation and customer service.

There are now 6 divisions within ACO Technologies that serve every sector of the construction industry, providing solutions for applications as diverse as rail, highways, airports, landscaping, retail, distribution centres and environmentally sensitive projects.



To help architects, designers and contractors meet the legal requirements that now tightly control the way surface water is managed, ACO has created its unique 'Surface Water Management Cycle' – Collect, Clean, Hold, Release – the four core processes now required for the complete and sustainable management of surface water drainage.



Contents

Introduction to ACO Q-Ceptor oil separators	4
ACO Q-Ceptor features overview	6
How to choose the correct separator	8
<hr/>	
ACO Q-Ceptor bypass oil separators	
ACO Q-Ceptor bypass oil separator - Design principles	10
ACO Q-Ceptor bypass oil separator chambers	11
ACO Q-Ceptor bypass oil separator accessories	12
<hr/>	
ACO Q-Ceptor full retention oil separators	
ACO Q-Ceptor full retention oil separator - Design principles	14
ACO Q-Ceptor full retention oil separator chambers	15
ACO Q-Ceptor full retention oil separator accessories	16
<hr/>	
ACO Q-Ceptor alarm systems	17
Installation	18
Guide to installing the ACO Q-Ceptor	20
Maintenance and servicing	22
Model specification clause	22



Introduction to ACO Q-Ceptor oil separators

Background

Protection of the environment is a crucial part of an integrated approach to modern surface water management and sustainable drainage systems (SUDS). Contamination of our ground water and watercourses from hydrocarbons (petrol, diesel and engine oil) carried by surface water runoff poses serious threats to the environment.

The SUDS approach requires “source control” of surface water runoff. Oil separators form part of this approach by treating surface water runoff on site prior to discharge into a watercourse or sewer system.

They work by separating oil contamination from water flows. Oil and silt are retained within the separator until they can be removed safely from the site, with the treated water being allowed to discharge.

Where are oil separators required?

Any site where there is a risk of surface water being contaminated by hydrocarbons needs to have measures in place to prevent pollution of the environment. Oil separators are installed on sites where there is a risk of accidental spillages or leaks of oil from vehicles or plant and machinery.

Under current legislation it is mandatory throughout the UK to prevent pollution and each site will need to consider the most appropriate measures required.

Typical sites at risk include:

- ▶ Car parks with 50 or more car parking spaces or larger than 800m².
- ▶ Smaller car parks discharging to environmentally sensitive areas.
- ▶ Areas where goods vehicles are parked or manoeuvred.
- ▶ Vehicle maintenance areas.
- ▶ Industrial sites where oil is stored or used.
- ▶ Refuelling areas.
- ▶ Any site with a risk of contamination from petrol, diesel, or engine oil.



Any site susceptible to surface water contamination needs to provide appropriate pollution prevention measures

Choosing the correct separator

In order to aid decision making as to whether an oil separator is required, and what type and size is appropriate, the Pollution Prevention Guidelines (PPG3) have been prepared and issued by the Environment Agency for England and Wales, the Scottish Environment Protection Agency, and the Environment and Heritage Service for Northern Ireland. A copy of the PPG3 flowchart which assists this decision is given on page 8.

Regulatory details

The ACO Q-Ceptor range of separators is on the Environment Agency's list of separators compliant with the Construction Products Regulations 1991 and conforms fully to the requirements of PPG3.

In addition, all ACO Q-Ceptor oil separators have been designed and independently tested to BS EN 858-1:2002 and BS EN 858-2:2003.

The ACO Q-Ceptor oil separator range

ACO Q-Ceptors are available in a range of chamber sizes and flow rates ideal for use in car parks, maintenance areas, and industrial and residential applications. Manufactured from polyethylene, the innovative single chamber design of the ACO Q-Ceptor is extremely compact and robust offering significant advantages in installation and handling costs over traditional GRP products.

ACO Q-Ceptors are available in two performance classes as specified by BS EN 858-1:2002.

Class 1

Class 1 separators are designed to achieve discharge concentrations of less than 5 mg/litre of oil under standard test conditions. These separators are required for discharges to surface water drains and the water environment.

The Class 1 ACO Q-Ceptor uses high performance coalescing filters positioned above the silt storage area, ensuring optimum performance under the harshest conditions. Under test conditions the ACO Q-Ceptor reduces concentrations to less than 1mg/litre of oil.

Class 2

Class 2 separators are designed to achieve discharge concentrations of less than 100 mg/litre of oil under standard test conditions. They are suitable for dealing with discharges where a lower quality requirement applies, for example where the sewer provider allows discharges to the foul system.

Both Class 1 and Class 2 ACO Q-Ceptors are available as bypass or full retention separators.

Bypass separators

ACO Q-Ceptor bypass separators fully treat all flows generated by rainfall rates of up to 6.5mm/hr. Flows above this level deemed "high flows" are allowed to bypass the separator. These separators are used when it is considered an acceptable risk not to fully treat these high flows, typically in areas where there is a small risk of spillage such as short stay car parks.

Full retention separators

ACO Q-Ceptor full retention separators treat the full flow typically generated by a rainfall intensity of 65mm/hr. Full retention separators are used where there is a risk of regular contamination with oil and a foreseeable risk of significant spillages e.g. vehicle maintenance areas.

ACO Q-Ceptor bypass and full retention oil separators are available in four sizes. For details of the sizes available, please refer to the features overview on the next page.



Why choose ACO Q-Ceptor oil separators?

- ▶ Class 1 and 2, full retention and bypass separators available
- ▶ Compliant with the Environment Agency's PPG3 guidelines
- ▶ Environment Agency verified manufacturer
- ▶ Independently certified range of sizes to BS EN 858-1 and BS EN 858-2
- ▶ Contractor friendly bypass connections for 160mm PVC-U, 225mm, 300mm and 375mm twinwall or clay pipe work
- ▶ Robust polyethylene construction for long service life and improved durability over GRP units
- ▶ Compact vertical design for ease of handling, installation and maintenance
- ▶ Maintenance friendly design, for simple operation and excellent accessibility
- ▶ In-chamber sampling capability removes the need for expensive separate sampling chambers
- ▶ Full range of quality oil, silt and high level alarm systems
- ▶ Light weight polyethylene extension shaft, easy to handle and install

ACO Q-CEPTOR FEATURES OVERVIEW

ACO Q-Ceptors have a range of key features which are common to both the bypass and full retention chambers and are numbered below. Bypass and full retention chambers each have a set of features specific to their product types. These features are highlighted on the product images below.

- 1 Compact design reduces excavation and installation costs
- 2 Highly durable polyethylene body, less prone to damage than GRP units
- 3 D 400 separator cover and frame available
- 4 Coalescing filter located for simple removal and maintenance. Unit can be cleaned by normal water pressure
- 5 Large diameter opening for easy maintenance access
- 6 Connection for optional sampling pump which obviates the need for separate and expensive sampling chambers
- 7 Extension shaft Ø716mm available

ACO Q-Ceptor oil bypass separators

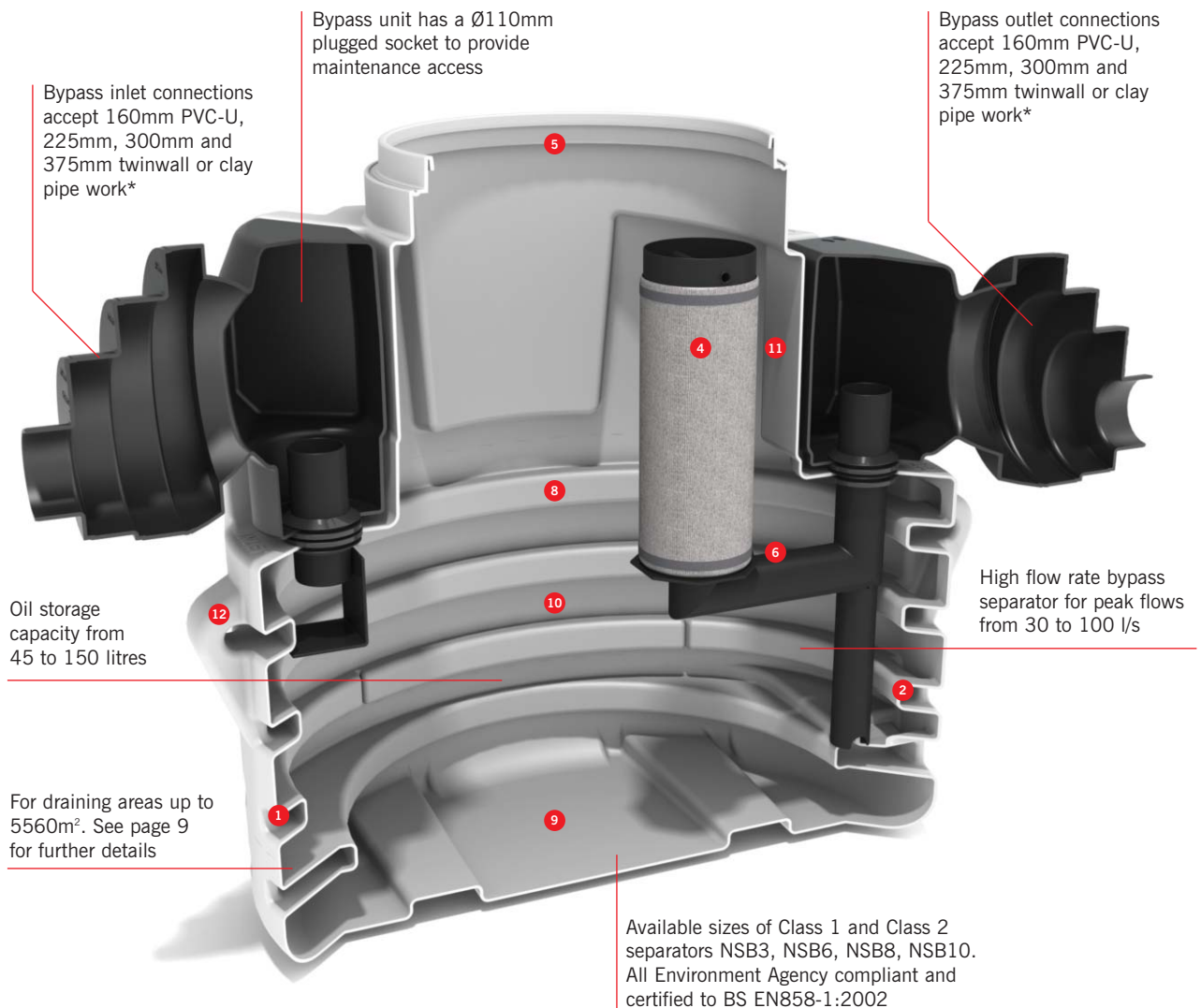

*For optimum performance of each bypass separator the pipe diameter stated in the chart on page 11 must be used. Using pipe diameters less than those stated will reduce the efficiency of the separator. Stated pipe diameters must not be exceeded.

- 8 Minimum working capacity of 1,000 litres excluding silt complies fully with PPG3
- 9 Flat base for stability during installation and levelling, with integrated lifting slots for forks
- 10 Ribbed body design resists deflection during installation and provides concrete key/anchors
- 11 Ø110mm vent connection
- 12 Integrated lifting holes for use with slings



Automatic warning alarms / devices

PPG3 requires all oil separators to be installed with a robust visual and audible warning device to indicate that the chamber needs emptying. ACO offer a complete range of oil, silt, and high level alarm systems. See page 17 for details.

ACO Q-Ceptor full retention separators

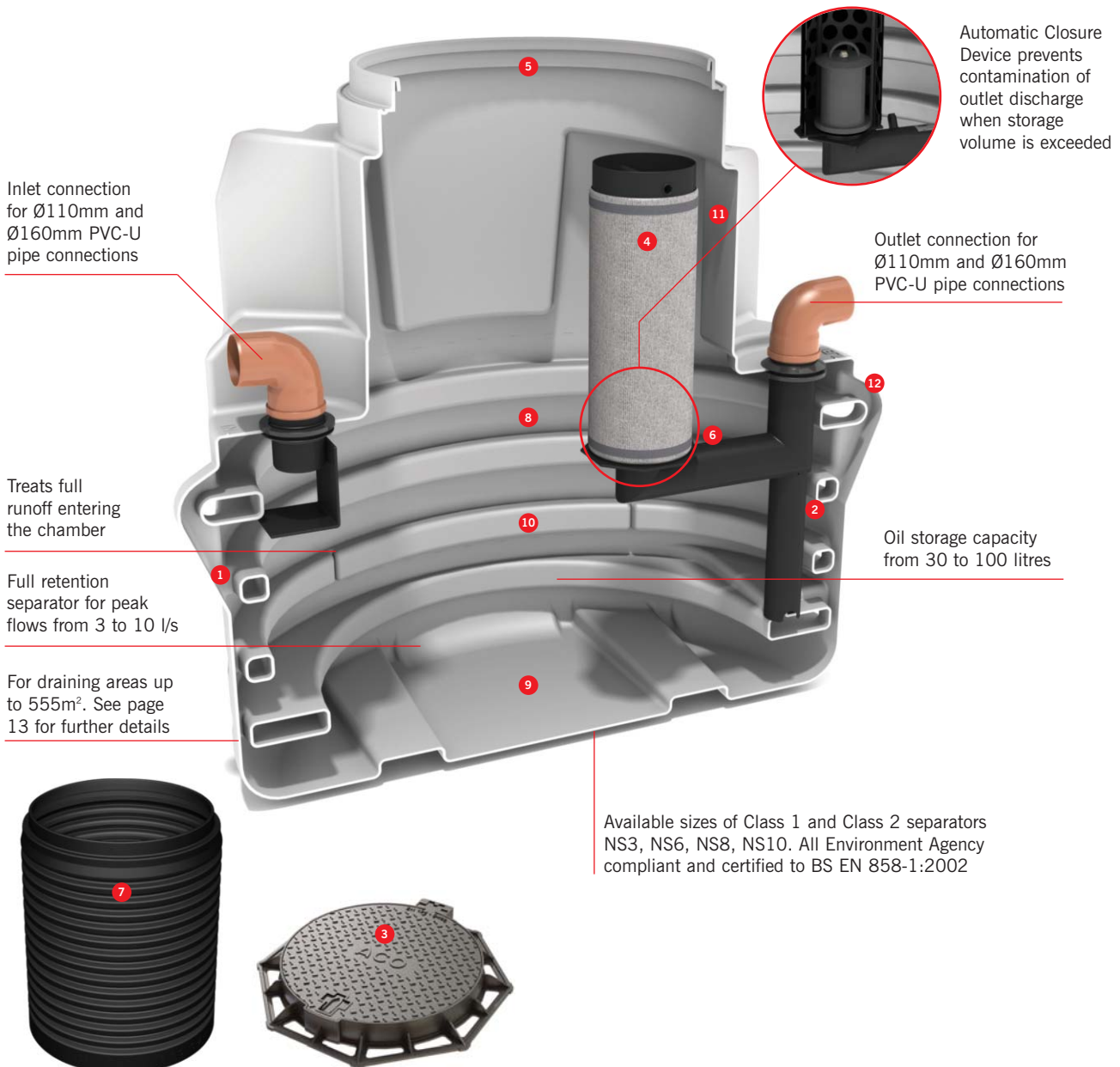

How to choose the correct separator

Use the flow chart to help you select the appropriate separator for your site. More than one separator might be required on larger sites or a site with many activities. You will need to consider local circumstances and risk factors including:

- the discharge point of your proposed separator
- the environmental sensitivity of your location
- activities on your site

PPG 3 advises that SUDS should be incorporated into the surface water drainage whenever possible. This is a legal requirement in Scotland. The introduction of a SUDS system may remove the requirement for an oil separator.

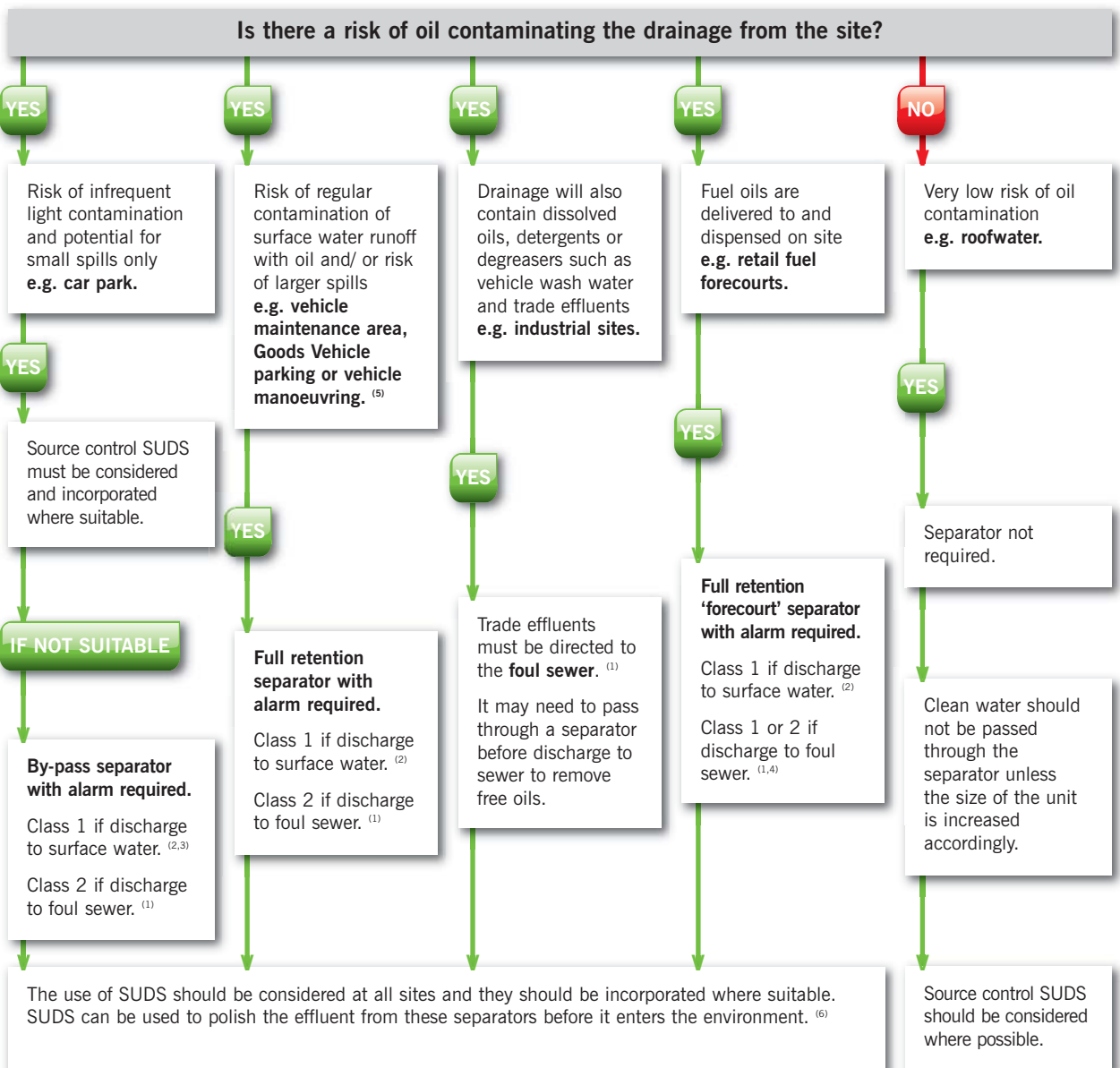

IMPORTANT NOTES:

1. Permission must be sought from local sewer provider before deciding which separator to install and before making discharge.
2. Prior permission must be sought from the Environment Agency before deciding which separator to install.
3. In this case, if it is considered that there is a low risk of pollution a source control SUDS scheme may be appropriate.
4. In certain circumstances, the sewer provider may require a Class 1 separator for discharges to sewer to prevent explosive atmospheres from being generated.
5. Drainage from higher risk areas such as vehicle maintenance yards and goods vehicle parking areas should be connected to foul sewer in preference to surface water.
6. In certain circumstances, a separator may be one of the devices used in the SUDS scheme. The Environment Agency should be contacted for further advice.

Environment Agency
 Tel: 08708 506 506
 Web: www.environment-agency.gov.uk

ACO Q-Ceptor bypass oil separators



BYPASS SEPARATORS

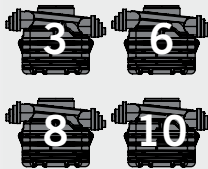

	Nominal size bypass (NSB)
5560*	Area drained (m ²)
3 - 10	Treated flow (l/s)
30 - 100	Peak flow (l/s)
1 & 2	Performance Class
45 - 150	Oil storage capacity (litres)
300 - 1000	Silt storage capacity (litres)

ACO Q-Ceptor bypass oil separators fully treat all flows caused by rainfall up to 6.5mm per hour which includes the vast majority of rainfall events in the UK.

In this scenario it is deemed acceptable not to treat the full flow, and where the worst pollutants will be carried off by the initial flow, for example car parks, roadways and some commercial areas.

Once 10% of the peak flow rate is exceeded, the flow bypasses the separation chamber and discharges directly into the drainage system.

*NSB 10

ACO Q-Ceptor bypass oil separator – Design principles

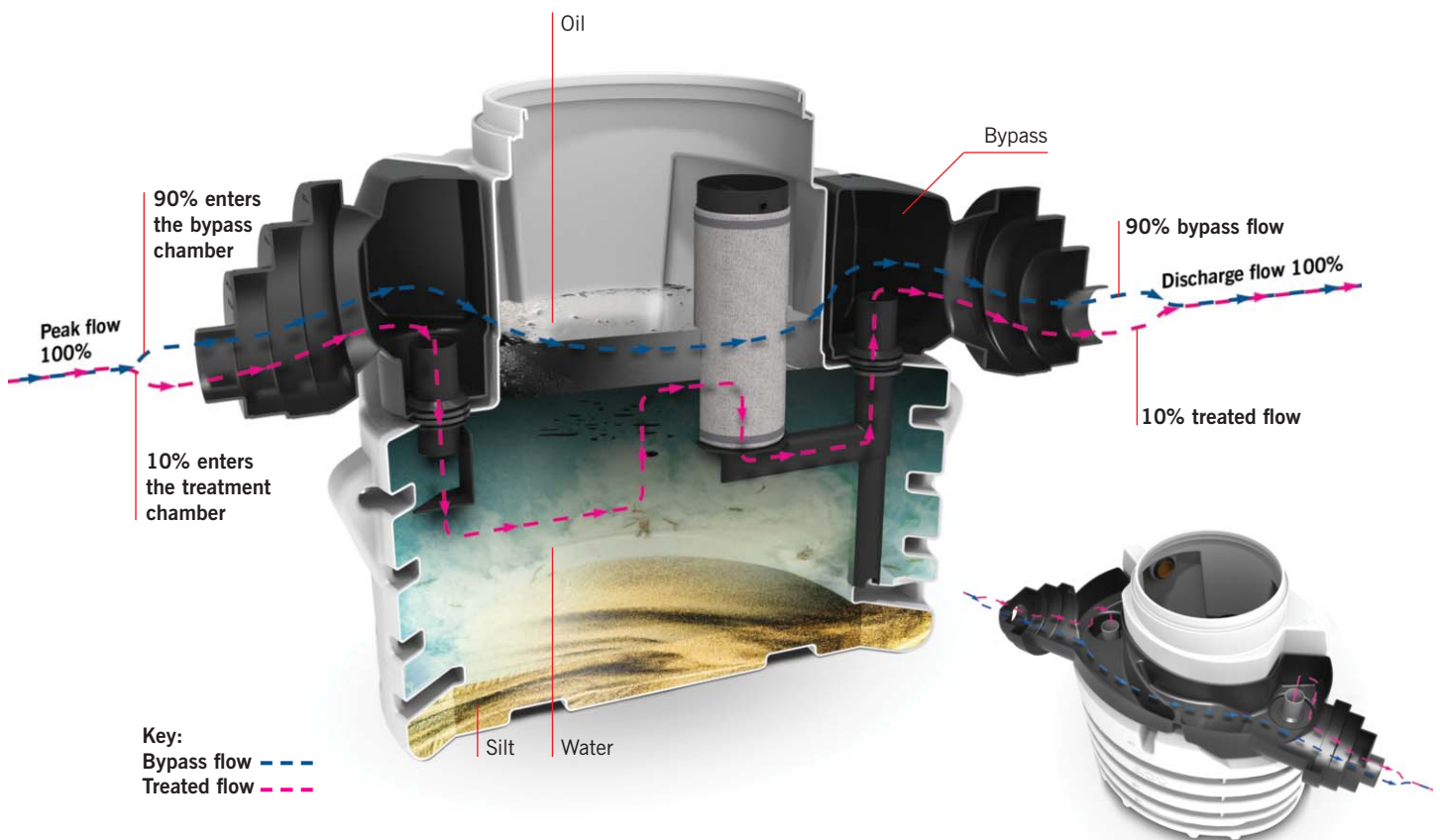

ACO Q-Ceptor bypass oil separators are designed to treat 10% of the peak flow into the unit. This 10% is known as the treated flow. Flows in excess of this 10% are allowed to bypass the treatment chamber.

Runoff entering the unit is retained within the treatment chamber for sufficient time to allow the oil carried in it to float to the top and for any silt in the water to settle to the bottom of the tank. The clean water remaining below the layer of floating oil discharges through the outlet.

The ACO Q-Ceptor bypass separator is designed with a bypass chamber around the top of the unit that permits flows in excess of the treated flow to bypass the treatment chamber.

Bypass units are permitted in locations where the risk of pollution is low, and in particular where the risk of a large volume of pollution is low. The reasoning behind this is that most rainfall in the UK is at an intensity of 0.0018 l/sm² or less, and all runoff from this light rain will pass through the treatment chamber.

In heavier rain, most of the pollution will be carried by the initial first flush of runoff, which will all be treated. As a result of this any pollution in the bypass flow at the peak of the storm will have been massively diluted.

ACO's design of bypass chamber ensures that no bypass will occur before the designed treated flow is reached. Thereafter, the treated flow will continue to pass through the unit, with excess flow (of up to 9 times the treated flow rate) allowed to bypass the treatment chamber.

ACO Q-Ceptor bypass oil separators are available to BS EN 858-1:2002 Class 1 or Class 2. When Class 1 effluent (better than 5 mg/l) is required, a coalescing filter is fitted to the unit. Without the coalescing filter the separators operate to Class 2 and achieve a treatment standard of better than 100 mg/l.

Maintenance

Regular maintenance is essential to ensure that a separator continues to operate to its full design capability throughout its working life. This maintenance includes monitoring the oil and silt levels, and removing any accumulated waste. Alarm systems are fitted to carry out this monitoring on a continuous basis. BS EN 858-2:2003 requires that a physical inspection must take place at intervals of no more than 6 months. The standard also requires that every five years the separator must be emptied and given a general inspection to test the integrity and performance of the system. The separator must be refilled with clean water following such an inspection.

ACO Q-Ceptor bypass oil separators

How to choose the correct size

ACO Q-Ceptor bypass separators should be sized in accordance with the guidance in PPG3.

The appropriate size of separator is calculated by applying a standard formula to the area to be treated. The precise formula depends on whether a full retention or bypass separator is to be used. In all cases the area to be drained is referred to as A.

The Nominal Size (NS) is the flow rate, in litres per second, which can be treated by the unit to the specified standard, Class 1 or Class 2. Bypass separators are referred to as NSB (Nominal Size Bypass).

Design Example 1: Sizing a bypass separator

Assume you have a car park of 3,000m². This is area A.

The nominal size of a bypass separator for a catchment of area A (m²) is obtained using the following formula:

$$NSB = 0.0018 \times A$$

Applying this formula to the car park of 3000m² gives a result of 5.4. Therefore this car park would require a bypass separator of size NSB6.

ACO Q-Ceptor bypass separators are available as Class 1 or Class 2 performance types. They are also available with or without a sampling pump pre-fitted to the units.

Part numbers for chambers without a sampling pump can be found in column A.

Part numbers for chambers with a sampling pump pre fitted can be found in column B.

Bypass separator chambers

Product Code A	Product Code B	Nominal Size	Treated Flow (l/s)	Peak Flow (l/s)	Performance Class	Area Drained m ²	Oil Storage Capacity (litres)	Silt Storage Capacity (litres)	Length Overall (mm)	Width Overall (mm)	Depth Overall (mm)	Inlet Height (mm)	Outlet Height (mm)	Pipe Internal Diameter* (mm)	Weight (kg)
34500	34560	NSB3	3	30	Class 1	1670	45	300	2300	1200	1580	1067	917	300	102
34501	34561	NSB6	6	60	Class 1	3335	90	600	2300	1200	1800	1287	1137	300	116
34502	34562	NSB8	8	80	Class 1	4445	120	1000	2300	1200	2100	1587	1437	375	130
34503	34563	NSB10	10	100	Class 1	5560	150	1000	2300	1200	2100	1587	1437	375	130
34505	34565	NSB3	3	30	Class 2	1670	45	300	2300	1200	1580	1067	917	300	99
34506	34566	NSB6	6	60	Class 2	3335	90	600	2300	1200	1800	1287	1137	300	111
34507	34567	NSB8	8	80	Class 2	4445	120	1000	2300	1200	2100	1587	1437	375	125
34508	34568	NSB10	10	100	Class 2	5560	150	1000	2300	1200	2100	1587	1437	375	125

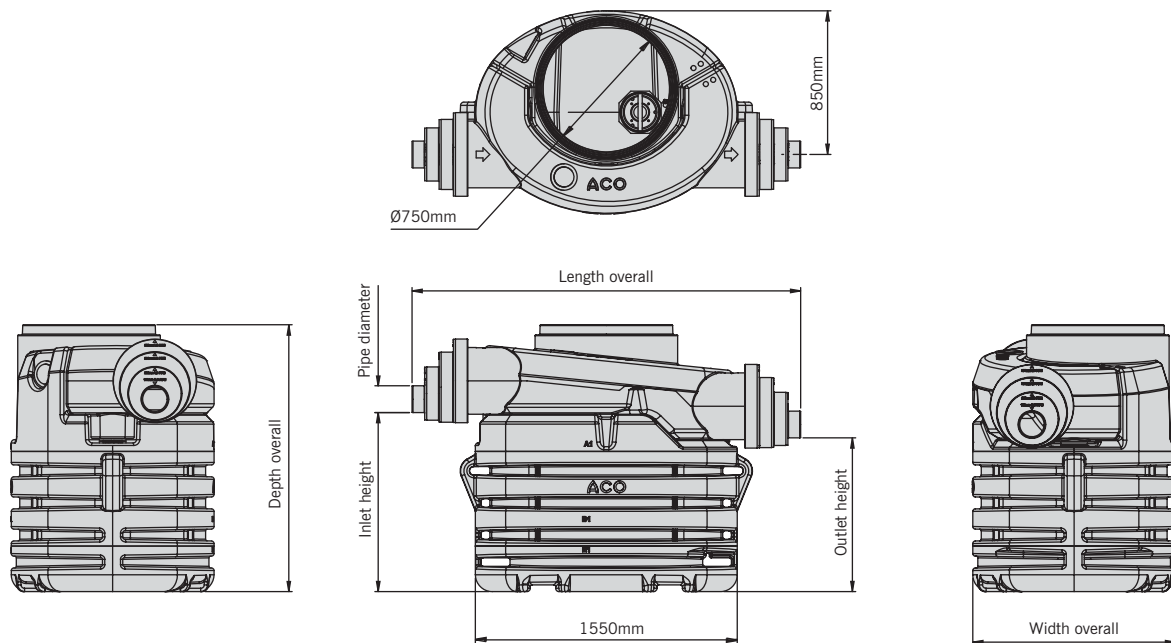

ACO Q-Ceptor bypass oil separator

*For optimum performance of each separator the pipe diameter stated in the chart must be used. Using pipe diameters less than those stated will reduce the efficiency of the separator. Stated pipe diameters must not be exceeded. Pipe internal diameters in the chart refer to twinwall or clay pipe work.

These products are subject to weight and dimensional tolerances. The dimensions shown on this page are for guidance purposes only.

ACO Q-Ceptor bypass oil separators

Cover and frame

Product Code	Description	Length (mm)	Width Overall (mm)	Depth Overall (mm)	Weight (kg)
34625	Ductile iron solid cover and frame D 400	-	Ø750	100	87.0

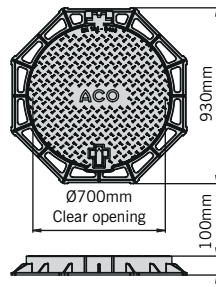

Cover and frame

Extension shaft

Product Code	Description	Internal Diameter (mm)	Length (mm)	Width Overall (mm)	Depth Overall (mm)	Weight (kg)
34520	Extension shaft	Ø716	-	Ø865	1059	19.1

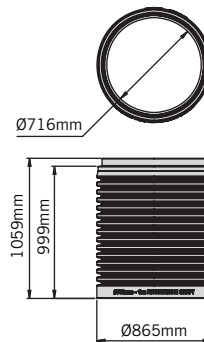

Extension shaft

Ancillaries

Product Code	Description	Length (mm)	Width Overall (mm)	Depth Overall (mm)	Weight (kg)
700745	Coalescing filter for NSB3	-	Ø230	660	1.2
700748	Coalescing filter for NSB6, 8 & 10	-	Ø360	790	3.6
418094	Sampling pump with 4m hose	-	-	-	3.5

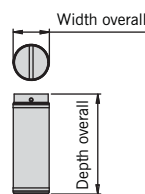

Coalescing filter



Stainless steel sampling pump with 4m hose

These products are subject to weight and dimensional tolerances. The dimensions shown on this page are for guidance purposes only.

ACO Q-Ceptor full retention oil separators



FULL RETENTION SEPARATORS

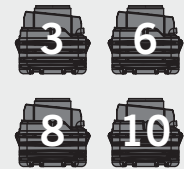

Nominal size (NS)

555*

Area drained (m²)

3-10

Peak flow (l/s)

1 & 2

Performance class

30-100

Oil storage capacity (litres)

300-1000

Silt storage capacity (litres)

*NS 10

ACO Q-Ceptor full retention oil separators treat the complete flow caused by rainfall up to 65mm per hour and where there is a high risk of contamination.

These separators hold the contaminated water for a period long enough to ensure that the lighter contaminates separate from the water and rise above it within the separation chamber. Micro particles are collected and combine on the coalescing filter until they are large enough to float free by themselves.

Full retention separators are used for example in vehicle maintenance and refuelling areas or scrapyards.



ACO Q-Ceptor full retention oil separator – Design principles

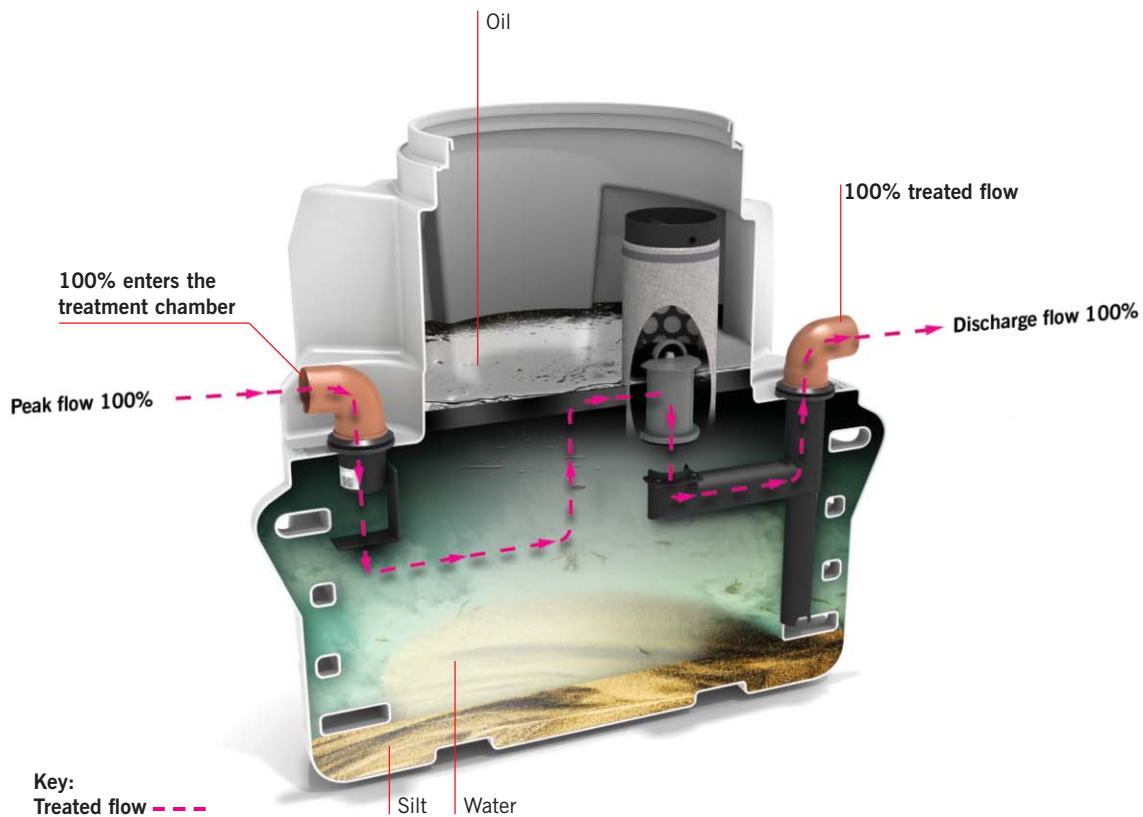

ACO Q-Ceptor full retention oil separators treat all flows to the required effluent standard, up to the designed flow rate of the unit.

Thereafter, in extreme rainfall events and at flow rates in excess of the design flow, the runoff will still flow into the treatment chamber until the maximum hydraulic capacity of the unit is reached.

Runoff entering the unit is retained within the treatment chamber for sufficient time to allow the oil carried in it to float to the top and for any silt in the water to settle to the bottom of the tank.

ACO Q-Ceptor full retention oil separators are available to BS EN 858-1:2002 Class 1 or Class 2. When Class 1 effluent (better than 5 mg/l) is required, a coalescing filter is fitted to the unit. This filter allows very small drops of oil that are too small to float upwards independently to coalesce into drops which are large enough to float up into the retained oil. Without the coalescing filter the separators operate to Class 2 and achieve a treatment standard of better than 100 mg/l.

ACO full retention separators are fitted with an Automatic Closure Device (ACD). This is a float which is weighted so that it floats in water but not in oil. The ACD ensures that if there is a large pollution event that fills the oil capacity of the separator (or if the unit is not being regularly maintained and the oil level builds up) then the outlet of the unit is closed and the oil retained in the unit cannot be washed out into the outflow system.

Maintenance

Regular maintenance is essential to ensure that a separator continues to operate to its full design capability throughout its working life. This maintenance includes monitoring the oil and silt levels, and removing any accumulated waste. Alarm systems are fitted to carry out this monitoring on a continuous basis. BS EN 858-2:2003 requires that a physical inspection must take place at intervals of no more than 6 months. The standard also requires that every five years the separator must be emptied and given a general inspection to test the integrity and performance of the system. The separator must be refilled with clean water following such an inspection.

ACO Q-Ceptor full retention oil separators

How to choose the correct size

ACO Q-Ceptor full retention separators should be sized in accordance with the guidance in PPG3.

The appropriate size of separator is calculated by applying a standard formula to the area to be treated. The precise formula depends on whether a full retention or bypass separator is to be used. In all cases the area to be drained is referred to as A.

The Nominal Size (NS) is the flow rate, in litres per second, which can be treated by the unit to the specified standard, Class 1 or Class 2. Full retention separators are referred to as NS (Nominal Size).

Design Example 2:

Sizing a full retention separator

Assume you have an HGV yard of 500m². This is area A.

The nominal size of a full retention separator for a catchment of area A (m²) is obtained using the following formula:

$$NS = 0.018 \times A$$

Applying this formula to the HGV yard of 500m² gives a result of 9. Therefore this yard would require a full retention separator of size NS10.

ACO Q-Ceptor full retention separators are available as Class 1 or Class 2 performance types. They are also available with or without a sampling pump pre-fitted to the units.

Part numbers for chambers without a sampling pump can be found in column A.

Part numbers for chambers with a sampling pump pre-fitted can be found in column B.

ACO full retention separator chamber

Product Code A	Product Code B	Nominal Size	Peak Flow (l/s)	Performance Class	Area Drained m ²	Oil Storage Capacity (litres)	Silt Storage Capacity (litres)	Length Overall (mm)	Width Overall (mm)	Depth Overall (mm)	Inlet Height (mm)	Outlet Height (mm)	Pipe Diameter (mm)	Weight (kg)
34510	34570	NS3	3	Class 1	167	30	300	1730	1200	1580	970	950	110	78
34511	34571	NS6	6	Class 1	333	60	600	1730	1200	1800	1218	1198	160	99
34512	34572	NS8	8	Class 1	444	80	1000	1730	1200	2100	1518	1498	160	113
34513	34573	NS10	10	Class 1	555	100	1000	1730	1200	2100	1518	1498	160	113
34515	34575	NS3	3	Class 2	167	30	300	1730	1200	1580	970	950	110	77
34516	34576	NS6	6	Class 2	333	60	600	1730	1200	1800	1218	1198	160	96
34517	34577	NS8	8	Class 2	444	80	1000	1730	1200	2100	1518	1498	160	110
34518	34578	NS10	10	Class 2	555	100	1000	1730	1200	2100	1518	1498	160	110

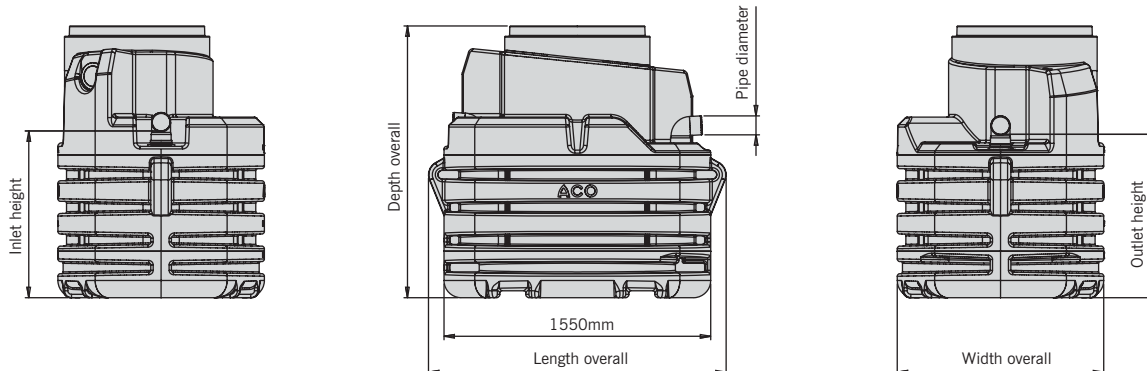
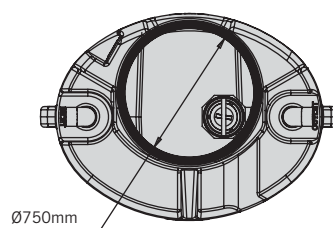

ACO Q-Ceptor full retention separator

These products are subject to weight and dimensional tolerances. The dimensions shown on this page are for guidance purposes only.

ACO Q-Ceptor full retention oil separators

Cover and frame

Product Code	Description	Length (mm)	Width Overall (mm)	Depth Overall (mm)	Weight (kg)
34625	Ductile iron solid cover and frame D 400	-	Ø750	100	87.0

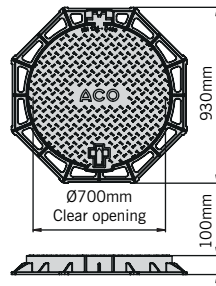

Cover and frame

Extension shaft

Product Code	Description	Internal Diameter (mm)	Length (mm)	Width Overall (mm)	Depth Overall (mm)	Weight (kg)
34520	Extension shaft	Ø716	-	Ø865	1059	19.1

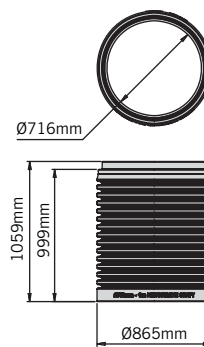

Extension shaft

Ancillaries

Product Code	Description	Length (mm)	Width Overall (mm)	Depth Overall (mm)	Weight (kg)
700745	Coalescing filter for NS3	-	Ø230	660	1.2
700748	Coalescing filter for NS6, 8 & 10	-	Ø360	790	3.6
701580	Automatic Closure Device (ACD) for NS3	-	Ø160	265	2.8
701583	Automatic Closure Device (ACD) for NS6, 8 & 10	-	Ø220	420	7.1
418094	Sampling pump with 4m hose	-	-	-	3.5

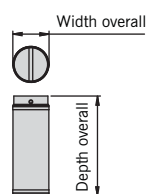

Coalescing filter

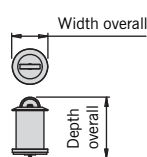

Automatic Closure Device (ACD)



Stainless steel sampling pump with 4m hose

These products are subject to weight and dimensional tolerances. The dimensions shown on this page are for guidance purposes only.

ACO Q-Ceptor alarm systems

BS EN 858-1:2002 and the Environment Agency's Pollution Prevention guidelines (PPG3) require that all oil separators must be fitted with an automatic alarm/warning device to provide visual and audible warning when the level of oil reaches 90% of the storage volume under static liquid level conditions. These alarms/warning devices indicate that the separator is in need of immediate emptying for it to continue to work effectively.

In order to meet this requirement, ACO offer a full range of visual and audible electronic alarm systems. The alarms are designed to continuously monitor the critical operating conditions of the separator and provide a warning early enough to prevent any discharge of pollutants into the environment. All the alarm systems can be fitted either during installation and commissioning of a new oil separator, or to existing installations.

The standard range of mains powered analogue alarm systems provides high levels of environmental safety, is simple to install and provides an economical solution where the necessary cabling and ducting can be provided. To ensure precise monitoring in any situation, all of the alarm systems can be fitted with up to three sensor probes within the separator for oil, silt and high liquid levels.

SPECIFICATION PROCESS

To simplify specification and ordering ACO provide alarm systems as complete installation sets. Each alarm system set consists of the following components:

- ▶ Sensor probes
- ▶ Control unit (with audible and visual warning)
- ▶ Housing for control unit
- ▶ Assembly accessories (including cable connector, fasteners and hangers)

ACO Q-Ceptor standard alarm system installation sets

Product Code	Description	Power Supply
34601	Separator alarm set with oil sensor probe	230V AC
34602	Separator alarm set with oil, silt and high liquid level sensor probes	230V AC
34603	Separator alarm set with oil and high liquid level sensor probes	230V AC

Note: All sensor probes of the alarm systems feature ATEX-approval, meaning they are approved for use in explosive areas of zone 0.



Alarm options

ACO can supply digital GSM alarm systems including mains, battery or solar powered units. GSM alarm systems are ideal for areas where people are not present and send an SMS (text) warning message via a GSM mobile phone network, offering 24/7 protection.

Battery and solar powered units give greater installation flexibility where oil separators are used in areas without a readily available power supply. For full details of available options please contact the ACO Water Management Design Services Team on 01462 816666.



Standard visual and audible warning function



Standard mains power (230 V AC)



Optional battery power operation (9 V DC)



Optional solar power operation (12-30 V DC)



Optional GSM TEXT warning to mobile phone

Installation notes

This section provides general installation notes for ACO Q-Ceptors that should be followed before installation. These notes should be read together with the recommended installation detail shown in the drawing on the following page.



In lightly loaded situations, the units can be installed without concrete backfill, using a suitable granular material as backfill. However a concrete slab is likely to be required over the unit and the unit will be particularly vulnerable to flotation in groundwater. Engineering advice should be sought.

The ACO Q-Ceptor range of separators is Environment Agency compliant and conforms fully to the requirements of PPG3. In addition, all ACO Q-Ceptor separators have been designed and independently tested to BS EN 858-1:2002 and BS EN 858-2:2003. The customer (or their client) is responsible for ensuring that the installation of the unit is in compliance with any regulatory requirements of the planning authorities, Building Control, Environment Agency, Water Company, national and European standards, etc.

Installation should only be carried out by an experienced and competent contractor. Electrical work (e.g. alarms) must only be carried out by a suitably qualified electrician.

Site conditions

These recommendations indicate the requirements for installation of ACO Q-Ceptors in typical site conditions. The customer should ensure that the requirements for their particular site conditions and anticipated loadings are met, taking Engineering advice where necessary.

Flotation

These recommendations assume that the unit is to be installed with a concrete backfill. Even with the minimum recommended thickness of concrete, the units, when empty, are vulnerable to flotation if the ground water level is high. Care must therefore be taken during installation, and consideration given as to whether additional concrete should be provided in wet locations.



Contractors are advised to obtain a copy of the full installation recommendations. To do so, please contact the ACO Water Management Design Services Team on 01462 816666 or email technical@aco.co.uk.

Installation detail

ACO Q-CEPTOR OIL SEPARATORS

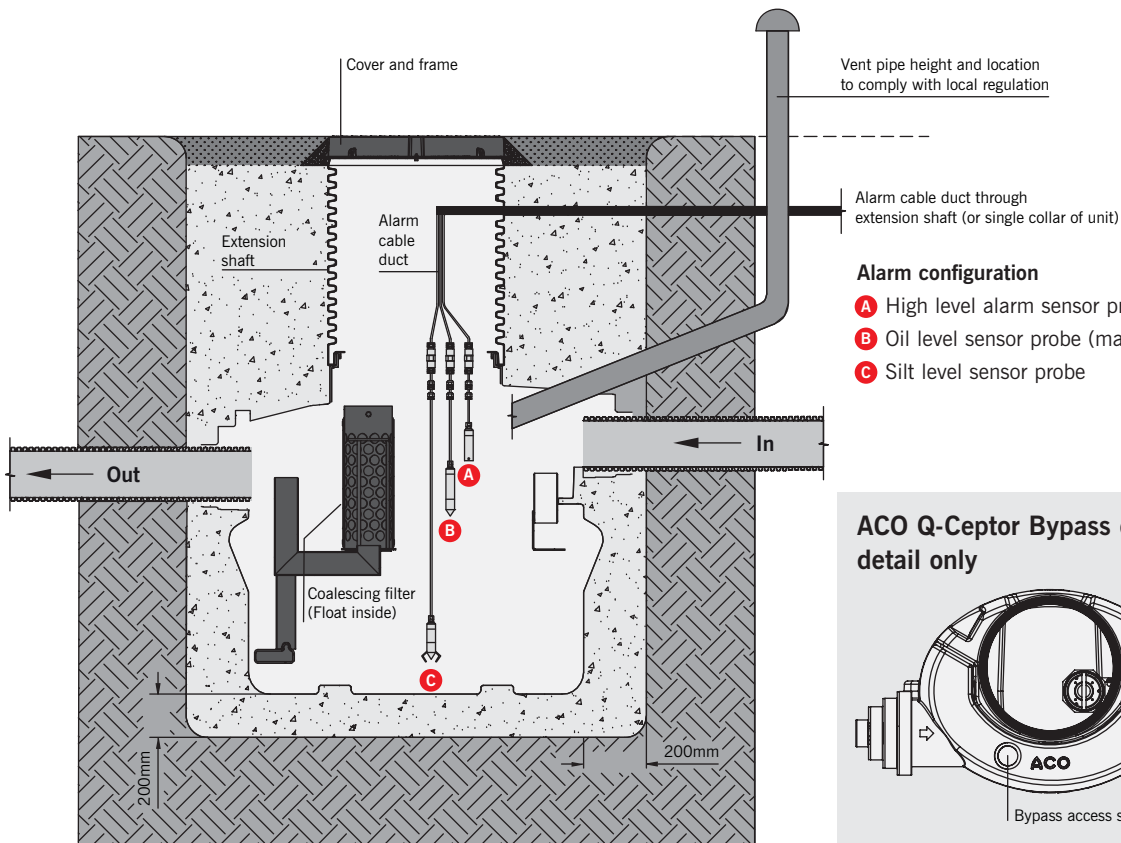

Alarm configuration

- A** High level alarm sensor probe
- B** Oil level sensor probe (mandatory)
- C** Silt level sensor probe

ACO Q-Ceptom Bypass chamber detail only

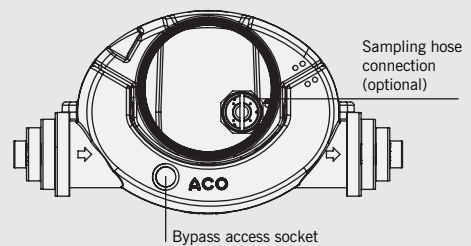

1. The customer should ensure that the requirements for their particular site conditions are met, taking engineering advice where necessary. These recommendations assume that the unit is to be installed with a concrete backfill.
2. Lift using a forklift through the slots under the base or webbing slings fixed through the lifting holes on the sides of the unit. Do not lift the unit using slings around the bypass channel. Take care that the units do not tip during handling. Do not drag, drop or roll the units. Store the units on firm level ground.
3. Excavate a hole to receive the unit, allowing for a minimum of 200mm thickness of concrete below and all around the unit and with sufficient working space for the connection of pipework, ducts and vents. Any unsuitable ground is to be removed and replaced. Engineering advice may be necessary. The excavation is to be kept free of water.
4. All concrete used in the installation is to be of minimum grade C16/20. Where necessary a higher specification of concrete may be required. Engineering advice should be sought. Pour a minimum 200mm thickness of concrete onto the base of the excavation, and whilst the concrete is still wet carefully lower the separator unit onto the concrete. Check that the unit is fully supported by the

concrete, is level and at the correct height. Check the orientation. Allow the concrete to harden.

5. Add 500mm depth of water to the inside of the unit. Carefully place additional concrete to the sides of the unit to a level between 400mm and 500mm above the base of the unit. Do not use vibrating pokers. Check that the unit is still correctly positioned and level. Allow this concrete to harden.
6. Add water to fill the unit to the invert of the outlet pipe. Carefully place additional concrete to the sides of the unit to a level just below the outlet pipe level, ensuring there is sufficient room left for the installation of the pipework. Allow this concrete to harden.
7. Connect the inlet and outlet pipework, vent pipe and bypass access pipe. The bypass separators have four possible pipe diameter connections. Cut the connection spigot at the appropriate location - see full installation recommendations for further guidance. Using pipe diameters other than those stated in the brochure and guidance will reduce the efficiency of the separator.
8. If an extension shaft is required, cut the shaft to the correct length and fit it to the top of the unit with sealant 8- 10mm thick.

9. Install a duct (with drawstrings) for the electrical cabling to the alarm.

10. Place further concrete backfill to the unit, in pours of maximum 500mm height allowing the concrete to harden between pours.

11. Fit the cover and frame.

12. If a sampling pump is to be fitted, fix the top hose clamp near to the underside of the cover and attach the hose to the top hose clamp.

13. Fit the alarm(s). This work is to be carried out by a qualified electrician. The alarm probes are to be hung at the correct levels, as shown in the detailed installation instructions.

14. Ensure any debris is cleared from inside the unit. Top up the unit with clean water. Fit the float (only required in full retention separators) and the coalescing filter (only required in Class 1 separators). Ensure that the float has floated up off its seating, (and if necessary lift it off its seating so that it is floating).



An electronic version of the ACO Q-Ceptom installation detail is available to download from the ACO website. Visit www.aco.co.uk.



Guide to installing the ACO Q-Ceptor

Step 1:

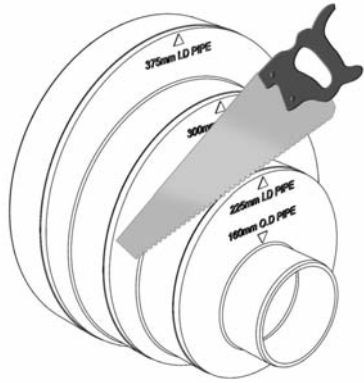

For a bypass separator, cut the connection collar to suit the required size of connecting pipework.

Step 2:



Excavate a hole 200mm wider and deeper than the separator chamber. Set the chamber to required level on a minimum 200mm deep bed of concrete (minimum grade 16/20). Ensure inlet and outlet are at the correct orientation and level. Allow concrete to harden.

Step 3:



Check the level of the inlet and outlet pipes and add approximately 500mm of water to the chamber. Haunch with between 400mm and 500mm of concrete. Once completed, check levels. Allow concrete to harden.

Step 4:



Add more water to the separator and backfill with concrete, keeping the water approximately 500mm above the concrete level. Fill the unit with water to the invert level of the outlet pipe. Backfill with concrete until the concrete is just below the outlet pipe level, ensuring that there remains adequate working room to fit the pipework.

Step 5:



Push connecting pipe into the collar and make good a joint with caulking and a suitable mortar or sealant. Fit bypass access pipe if required. Connect the vent pipe. Connect alarm cable duct through extension shaft (or neck of separator) and seal.

Step 6:

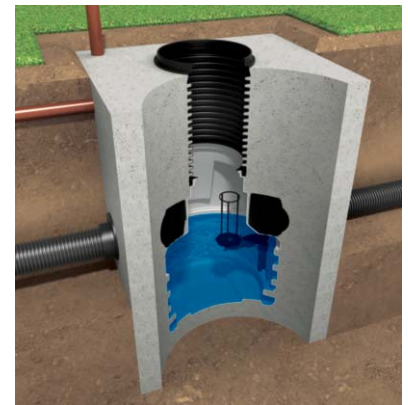

Fit extension shaft if required and cut to correct height, using sealant to ensure a watertight joint between the shaft and the separator. Complete fitting of the sampling pump hose (if required). Backfill with concrete in 500mm steps, allowing concrete to harden between pours. Brace the inside of the extension shaft if necessary to avoid distortion during the concrete pours. Continue until final concrete level is reached (just below underside of cover frame).

Step 7:

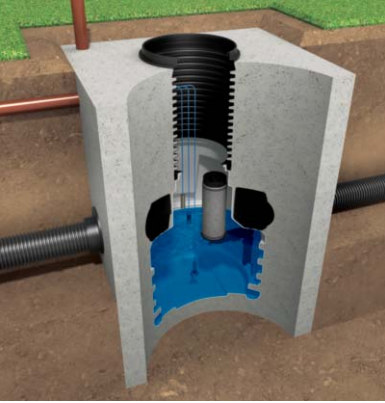

Trim extension shaft to correct height. Fit the cover frame. Fit the alarm system in accordance with the manufacturer's installation recommendations – this should be carried out by a qualified electrician. Lower the ACD into position (full retention separators only). Lower the filter into position (Class 1 separators only).

Step 8:

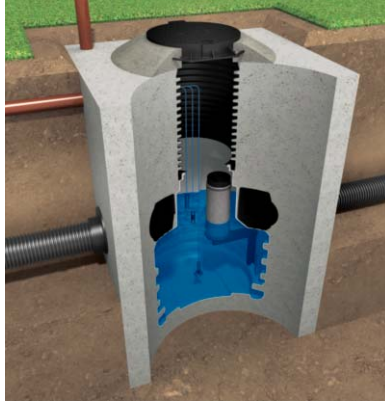

Ensure that the unit is free from all debris and fill with water to the outlet level. Ensure that the float is floating (if applicable) and the filter is correctly positioned (if applicable). Fit the cover.



Maintenance and servicing

In order to ensure the reliable functioning of oil separators and ongoing environmental protection they require regular maintenance and servicing. Unless this is done, environmental damage and the resulting risk of liability cannot be prevented.

ACO service partners work closely with the UK Environment Agencies and are able to offer ongoing maintenance and servicing programmes, waste disposal, inspection, testing and full installation and commissioning of oil separators and alarms. For further details please contact the ACO Water Management Design Services Team on 01462 816666.

Model specification clause

The oil separator shall be an ACO Q-Ceptor Oil Separator supplied by ACO Water Management, [Full Retention or Bypass], [size NS* or NSB*], [Class 1 or Class 2#]. The unit shall be manufactured from High Density Polyethylene and include (for Class 1 separators) a coalescing filter manufactured from polypropylene fibres reinforced with stainless steel wire and include (for full retention separators) a weighted float automatic closure device. The unit is to be designed and manufactured in accordance with BS EN 858-1, and is to conform to the recommendations in the Environment Agency Guidelines PPG3.

The oil separator is to be installed in accordance with the manufacturer's recommendations.

* insert nominal size as required
insert the required option

NBS Specifications

ACO Q-Ceptor Oil Separator should be specified in section R12:421. Assistance in completing this clause can be found in the ACO Water Management entry in NBS Plus, or please contact the ACO Water Management Design Services Team.

Note: A specification in NBS format is available to download from www.thenbs.com or www.aco.co.uk.



Recycling

All the components of ACO Q-Ceptor are recyclable. Separate the units into the plastic and metal parts and recycle in accordance with local regulations.



Certification

ACO Q-Ceptor oil separators are fully certified to BS EN 858-1:2002 and BS EN 858-2:2003.

Test certificates are available on request. Please contact the ACO Water Management Design Services Team on 01462 816666 for further information.

BS EN 858-1:2002

BS EN 858-2:2003

Notes

ACO Technologies plc

- ACO Water Management
Civils + Infrastructure
Urban + Landscape
- ACO Building Drainage
- ACO Sport
- ACO Wildlife

ACO Water Management: Civils + Infrastructure

A division of ACO Technologies plc
ACO Business Park,
Hitchin Road,
Shefford,
Bedfordshire
SG17 5TE

Tel: 01462 816666
Fax: 01462 815895

e-mail Enquiries: awmenquiries@aco.co.uk
e-mail Sales: customersupport@aco.co.uk
e-mail Technical: technical@aco.co.uk

website: www.aco.co.uk

The ACO Group: A strong family you can depend on.

© October 2013 ACO Technologies plc. All reasonable care has been taken in compiling the information in this document. All recommendations and suggestions on the use of ACO products are made without guarantee since the conditions of use are beyond the control of the Company. It is the customer's responsibility to ensure that each product is fit for its intended purpose, and that the actual conditions of use are suitable. This brochure and any advice is provided by ACO Technologies plc (the Company) free of charge and accordingly on terms that no liability including liability for negligence will attach to the Company or its servants or agents arising out of or in connection with or in relation to this brochure or any such advice. Any goods supplied by the Company will be supplied solely upon its standard conditions of sale, copies of which are available on request. The Company's policy of continuous product development and improvement renders specifications liable to modification. Information provided in this brochure is therefore subject to change without prior notification.

ACO CARES ABOUT THE ENVIRONMENT

Printed on material approved by the Forest Stewardship Council (FSC) who provide a means of assuring that products come from responsibly managed forest.



ISO 9001
FM 13502



ISO 14001
EMS 538781



OHSAS 18001
OHS 524145