

Split-it PRO
Split-it ON

Defining spaces

Split-it Pro

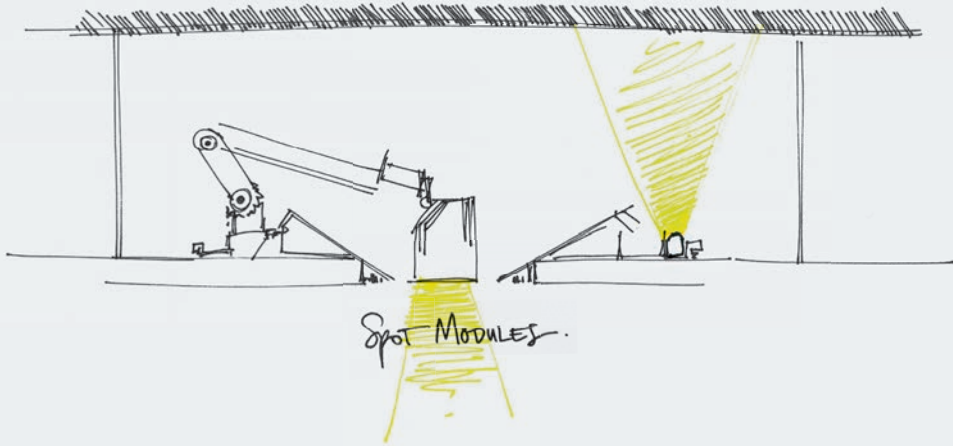
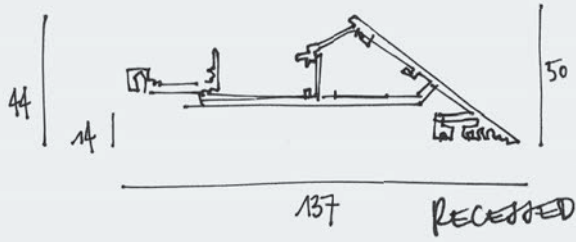

CORNERS & CORNER SETS *

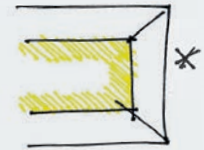
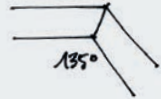
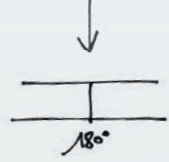

Split-it ON

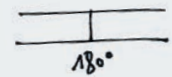
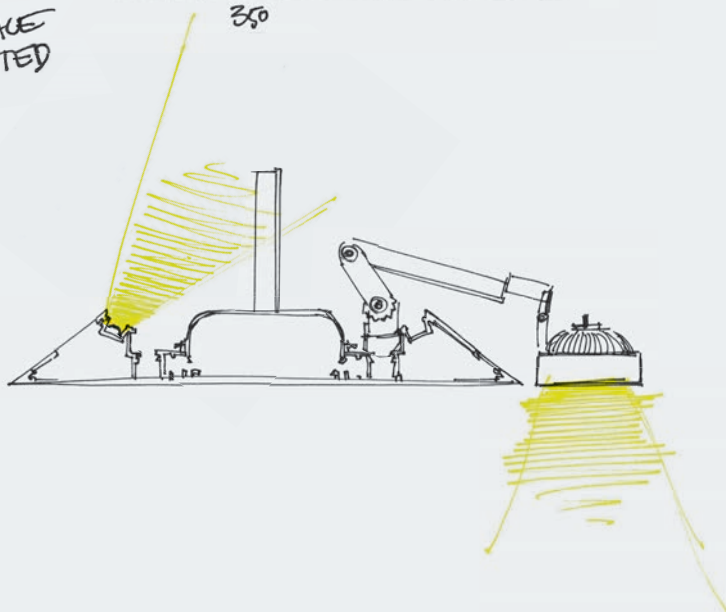
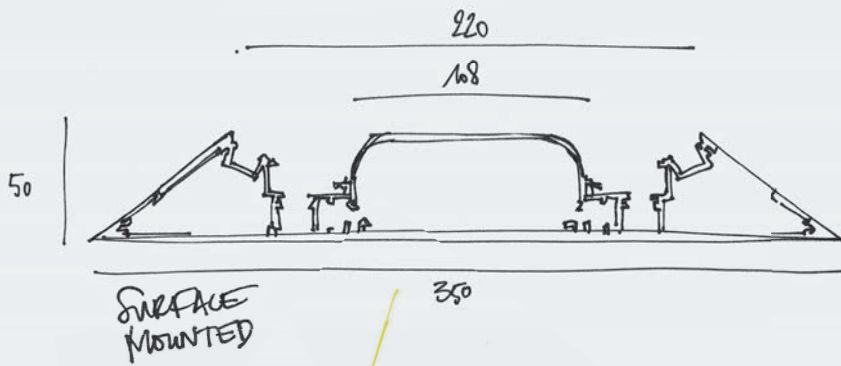

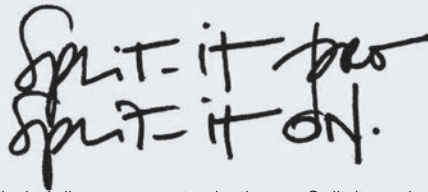
The image shows two lines of handwritten text in black ink on a light grey background. The first line reads "Split-it pro" and the second line reads "Split-it on.". The handwriting is casual and expressive, with some letters overlapping.

With their linear geometry, both new Split-it made-to-measure profiles enable you to define spaces and create volumes, to show direction, frame the room and add sharp edged detail to your architecture.

www.deltalight.com/split-it-on
www.deltalight.com/split-it-pro

Get inspired on different applications
in our Virtual Reality spaces:
www.deltalight.com/vr

See the video at
play.deltalight.com/splititpro

Split-it pro.

The Split-it PRO profile concept demonstrates that form and functionality of recessed lighting have definitely gone down a new path, opening new ways to integrate "lighting paths" with architecture. The Split-it is a single profile which can be used on its own, or in combination of two.

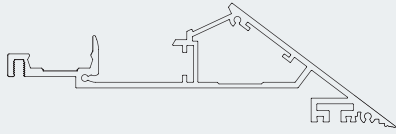

CORNER SETS.

With U-shaped corner sets of 90mm and 150mm, 180° connections, and 90° inner and outer corners available it becomes easy to create your linear patterns throughout the room, or to connect different spaces using the Split-it profile as a guidance tool.

You can simply define your desired lengths, list your corner elements, order and go.

U-CORNER 150mm.



90° IN



90° OUT



U-CORNER 90mm

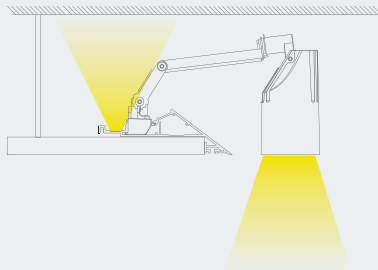

The Split-it PRO enables integration of edgeless lighting paths, either vertically or horizontally. Its 37° degree sharp edge gives walls and ceilings a 'paper-thin' appearance, with no visible wires and no shadow gaps, upgrading the level of architectural detail. It offers not only new ways to give shape to any lighting need, it also gives the possibility to integrate other engineering and technological necessities.

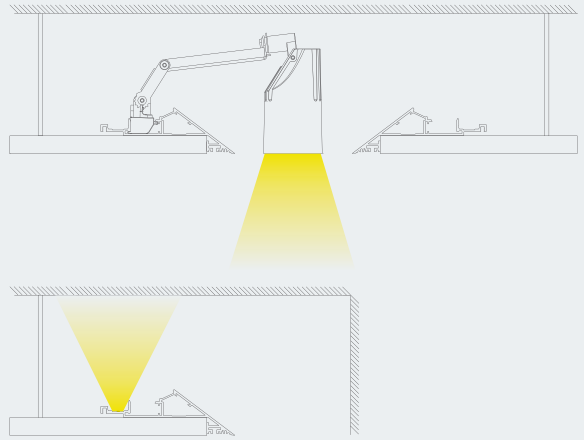



PERFORATED SCULPTURE

SPILT

Split-it ON.

The Split-it On is a made-to-measure profile for surface mounted application. It combines the extreme versatility of the recessed version, adding extra flexibility with the miniature Split-it On downlight module.

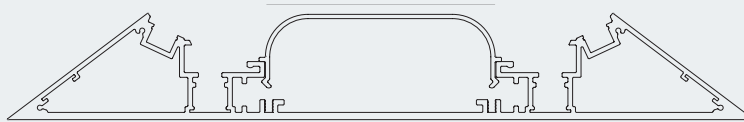

Two fixation options are available: direct fixation or suspension cables, enabling you to customize the position of the profile. Perfect to create continuous planes of light in spaces with changing ceiling heights.

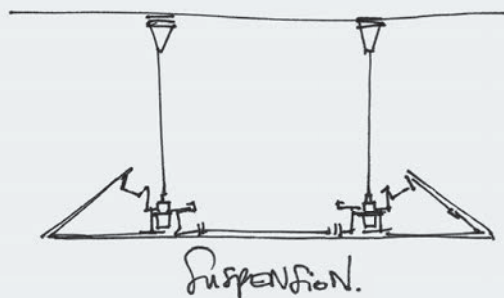
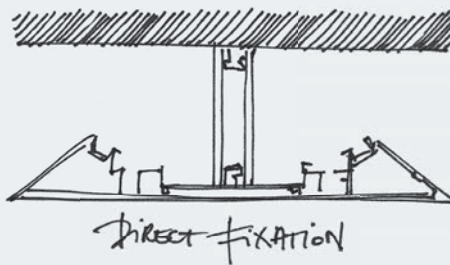



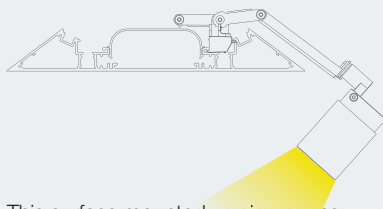

This surface mounted version opens up a new world of lighting scenarios for spaces with demanding lighting needs and ceiling limitations. Be it retail, meeting rooms, circulation areas, public buildings or other, the Split-it On caters for any lighting scenario you have in mind, without compromising the elegance and style of your project.



Split-it ON/PRO MODULE.

Both profiles can be combined with a multitude of spots available for specific and demanding lighting needs. Ranging from 800lm to 2900lm, beams ranging from 11° up to 57°, and different light sources.



Modules available in **CRI 80, 90** and up to **CRI 97** for industry leading colour rendering and consistency.

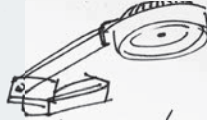

HANGEN /
LED REPLACEMENT LAMP.

SPLIT-IT RB111

SPLIT-IT SPY

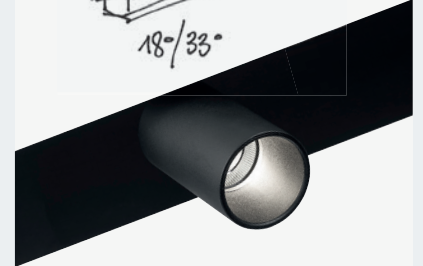
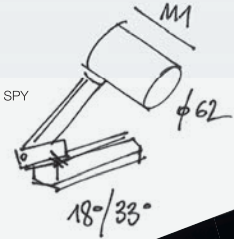

SPLIT-IT PINTOR 63

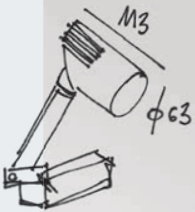

16°/18°/33°/43°/55°
SOFT DIM 40°

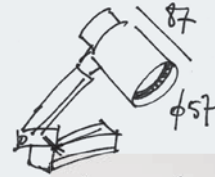

HANGEN /
LED REPLACEMENT LAMP.

SPLIT-IT RB50

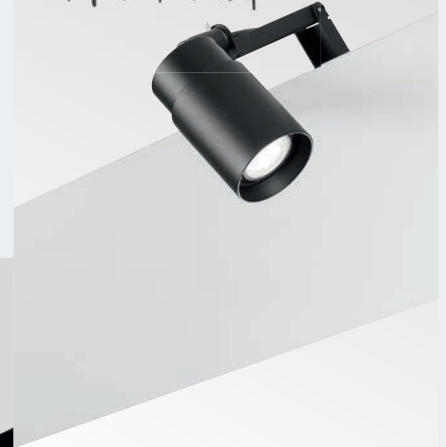

through
wiring.

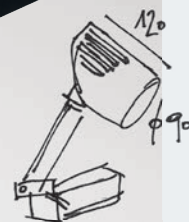
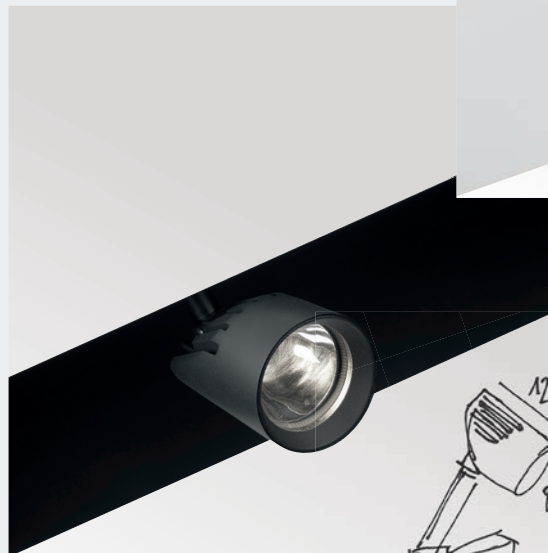
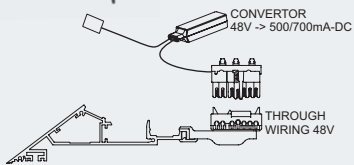

11°/20°/24°/35°/42°/57°

SPLIT-IT PINTOR 90

TOOL FREE!

Positioning of the modules

Simply by pressing a pin you can control the position of the arm of the module.

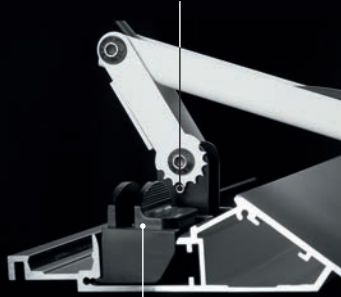

Via a clamp-system you can easily position the module along the full length of the profile.

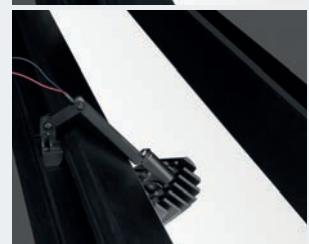

The mounting arm features three toolfree joints enabling maximum flexibility. The direction of the luminaire can manually be determined to highlight elements in the room.

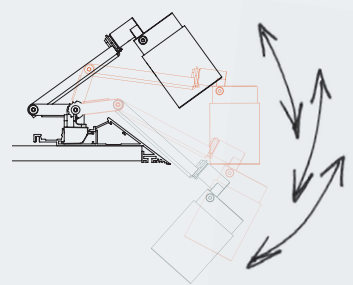

LIGHT-REFINING ACCESSORIES.



Wide range of light refining accessories available:



POSITION OF ACCESSORY



TUBE



HONEYCOMB

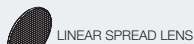

LINEAR SPREAD LENS



SPREAD LENS

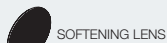

SOFTENING LENS



GLASS SBL





SPLIT-IT ON DOWNLIGHT

To complete all possible lighting needs spots and indirect lighting can be combined with **miniature downlight modules**, encapsulated within the profile to complete all possible lighting needs.

Despite its miniature size these downlight modules provide a powerful downlight output, perfect to illuminate tables or desks positioned below the profile.

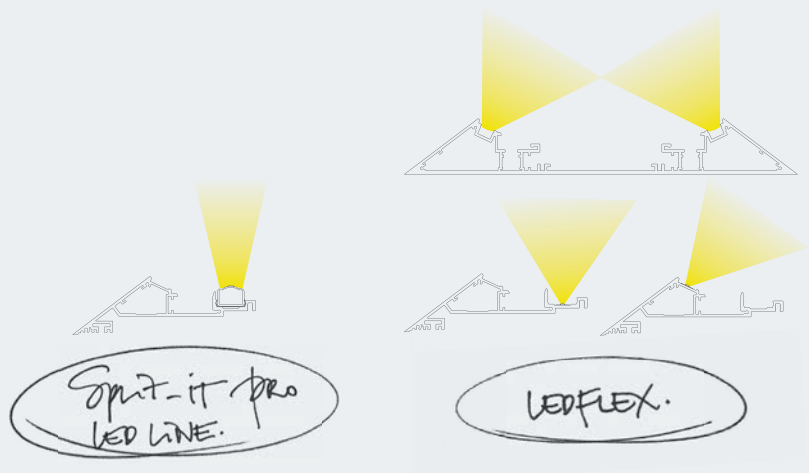

Both **Split-it ON** and **Split-it PRO** can be equipped with indirect lighting in 2 positions. This enables you to customize the indirect lighting effect, or to combine a white led line with RGB to create different atmospheres.

You can opt for a toolfree installation with the Split-it PRO LED LINE, or for LedFlex in Tunable White, Neutral White (4000K), Warm White (3000K), Halogen White (2700K) or RGB.



PRIVATE RESIDENCE - SARONNO (IT)

