

Uniclass L2123 + L7315	EPIC J3413
Cl/SfB (52.5)	

# ACO Drain

ACO MultiDrain™ MD



*ACO MultiDrain™ MD – channel drainage system*

## Technical Data



# ACO MultiDrain™ MD System

## Technical Data

### Contents

ACO MultiDrain™ MD – introduction to the system	Page 3
Channel range layout	Page 4

#### ACO MULTIDRAIN M100D SYSTEM

ACO M100D channels with UltraSTEEL™ galvanised edge rails	Page 6
ACO Universal Gully	Page 8
ACO Drainlock™ Gratings	Page 9
ACO M100D gratings	Page 10
ACO M100DS channels with stainless steel edge rails	Page 12
ACO M100DS gratings – stainless steel	Page 14

#### ACO MULTIDRAIN M150D SYSTEM

ACO M150D channels with UltraSTEEL™ galvanised edge rails	Page 15
ACO M150D gratings	Page 17
ACO M150DS channels with stainless steel	Page 18
ACO M150DS gratings – stainless steel	Page 20

#### ACO MULTIDRAIN M200D SYSTEM

ACO M200D channels with UltraSTEEL™ galvanised edge rails	Page 21
ACO M200D gratings	Page 23
ACO M200DS channels with stainless steel edge rails	Page 24
ACO M200DS gratings – stainless steel	Page 26

#### ACO MULTIDRAIN: PROBLEM SOLVING DRAINAGE SOLUTIONS

Discreet slot drainage	Page 27
Channel footpath drainage	Page 32

ACO MultiDrain™ MD Accessories – features, functions and benefits	Page 35
Design Method	Page 38
Hydraulic Performance tables	Page 39
Installation details	Page 45
Chemical Resistance Chart	Page 46
Specification Clause / Recycled Content / CE Conformity	Page 47



# ACO MultiDrain™ MD - Introduction to the system

ACO MultiDrain™ MD benchmarks a new approach in the planning, delivery and installation of general purpose channel drainage systems. Designed to provide an effective solution for a wide variety of applications, ACO MultiDrain™ MD system maximises functionality whilst using the minimum number of components.

The ACO MultiDrain™ MD polymer concrete channel drainage system is available in three widths; 100mm, 150mm and 200mm, and has a variety of depths and slopes. The channel units are certified to BS EN 1433: 2002 Load Class D 400\* and form the main components of the system.

Depending on the load class and application requirement, a wide range of gratings are available to complete the system. You can now choose from a range of traditional and discreet slot drainage gratings, solid covers and cross footpath drainage units to ensure all applications are catered for.

All gratings within the system are fitted with ACO Drainlock™, a bar-less locking device which reduces the risk of blockage and improves hydraulic capacity. The mechanism also provides for easy installation and maintenance of the system.

## Applications:

- ▶ Commercial developments
- ▶ Discreet slot drainage
- ▶ Footpath drainage
- ▶ Landscaping
- ▶ Light industrial units
- ▶ Pedestrian precincts
- ▶ Private and public parking areas
- ▶ Residential developments
- ▶ Retail developments
- ▶ Sports and leisure
- ▶ Services ducts
- ▶ Schools
- ▶ Threshold drainage



## Environmental considerations

All materials used in the manufacture and packaging of this system are 100% recyclable. In using the latest finite element analysis design packages, ACO have ensured minimum materials have been used for maximum performance.





The lightweight design not only aids installation but reduces carbon emission linked with the transportation of this product.

## Problem solving drainage solution

ACO MultiDrain™ MD can provide a drainage solution for more specific and challenging applications.

Discreet slot, threshold and cross footpath drainage solutions can be supplied by selecting the appropriate channel, grating and accessories. Drainage solutions for these specific applications are detailed towards the end of this brochure.

## ACO MULTIDRAIN MD IS SUITABLE FOR THE FOLLOWING APPLICATIONS:

Installation group	Load Class	Maximum Test Load (kN)	Vehicle	Typical Uses
1	 A 15	15	Pedestrians and Cycles	Pedestrian, cycleways and domestic drives
2	 B 125	125	Cars and Vans	Pedestrian precincts, light vehicles, private car parks and drives
3	 C 250	250	Light Commercial Vehicles	Parking areas, service stations (cars) and slow-moving light commercial vehicles
4	 D 400	400	HGVs	Parking areas for all types of vehicles*.

\*The ACO MultiDrain™ MD system is not suitable for carriageways of public roads or motorways.

# ACO MultiDrain™ MD System

## Technical Data

### Channel range layout

To support a wide variety of catchment depths, hydraulic capacities and applications, the system is available in three channel widths, 100mm, 150mm and 200mm and has a range of constant depths, shallow depth and sloping depth channels to suit the drainage design.

The layout below illustrates the channels and accessories available within the ACO MultiDrain™ MD range and to aid product selection, a summary of the function and feature of each component is provided.

All ACO MultiDrain™ MD channels can be purchased with galvanised or stainless steel edge rails.

Further details can be found on pages 6 – 33 of this brochure.



#### 1 Shallow depth channels



- ▶ **100mm wide bore:** Four shallow channel units are available in 1m lengths with an overall depth of 75mm or 100mm.
- ▶ **150mm wide bore:** One shallow channel unit is available in 1m length with an overall depth of 100mm.
- ▶ **200mm wide bore:** One shallow channel unit is available in 1m lengths with an overall depth of 100mm.

Standard option available includes vertical cast-in TPE seal for connection to Ø110mm pipework.

#### 2 Constant depth channels



- ▶ **100mm wide bore:** Four constant depth channel units are available in 1m lengths with overall depths ranging from 150mm to 300mm.
- ▶ **150mm wide bore:** Three constant depth channel units are available in 1m lengths with overall depths ranging from 210mm to 310mm.
- ▶ **200mm wide bore:** Three constant depth channel units are available in 1m lengths with overall depths ranging from 265mm to 365mm.

These channels include a vertical knockout for connection to Ø110mm (100mm wide bore channels) or Ø160mm (150mm and 200mm wide bore channels) pipework.

#### 3 Constant depth channels – 0.5m



- ▶ **100mm wide bore:** Four 0.5m constant depth channel units are available with overall depths ranging from 150mm to 300mm.
- ▶ **150mm wide bore:** Three 0.5m constant depth channels with overall depths ranging from 210mm to 310mm.
- ▶ **200mm wide bore:** Three 0.5m constant depth channels with overall depths ranging from 265mm to 365mm.

These channels include vertical knockout for connection to Ø110mm (100mm wide bore) or Ø160mm (150mm and 200mm wide bore) pipework and side knockout for 90° channel connections.



**4 Universal Sump**



Each system width has one 0.5m universal sump for connection to all channels. Outlet options for Ø110mm and Ø160mm pipes and foul air traps. Plastic silt bucket provided with each unit.

**5 Sloping depth channels**



▶ **100mm wide bore:** Twenty 1m sloping channels with 0.5% fall in depths from 150mm to 250mm.

**6 Universal gully**



One universal gully for all applications and channel widths from Load Class A 15 to D 400.

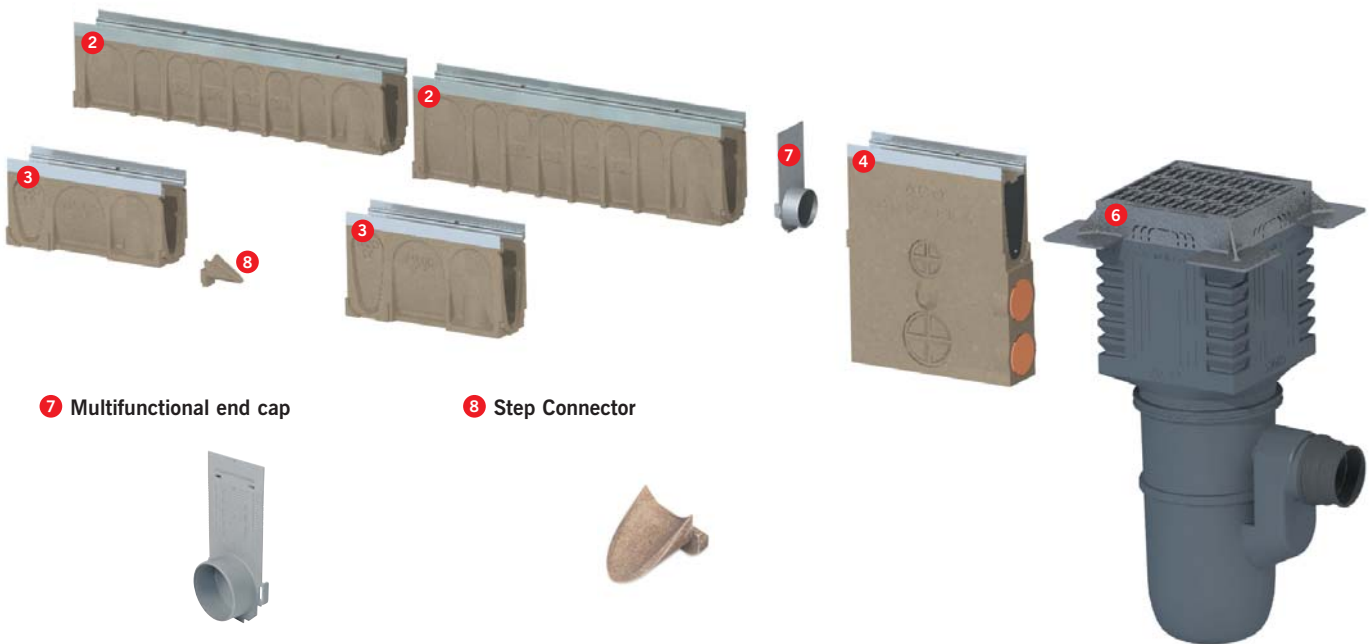

**7 Multifunctional end cap**



One plastic universal end cap for each channel width. Provides a closing or outlet option to Ø110mm (100mm wide bore channels) or Ø160mm (150mm and 200mm wide bore channels) pipes.

**8 Step Connector**



A polymer concrete unit which helps provide smooth water transition between constant depth channels when used in a stepped system design. The step connector is suitable for the 50mm step between each of the constant channel depths.



**Guidance for using the ACO MultiDrain™ MD parts tables**

The ACO MultiDrain™ MD parts tables are shown on the following pages. The product information is split down by channels widths and further by channel depth and edge rail type. This is to enable quick and simple product identification and selection.

The tables for ACO MultiDrain™ MD channels list a number associated with the Invert Type. This number highlights the drainage design which can be achieved when using these channels. The key for the Invert Type is shown opposite.

**Channel invert types**



1 Constant Depth Invert

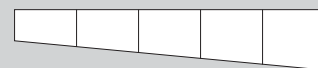

2 Sloping Invert



3 Stepped Invert

# ACO MultiDrain™ MD System

## Technical Data

### ACO MultiDrain™ M100D channels with UltraSTEEL™ galvanised edge rails.

ACO MultiDrain™ M100D channels are manufactured from polymer concrete, a tough and robust material which provides high chemical resistance. The channels are available in constant depth, sloping depth and shallow depth units.

ACO MultiDrain™ M100D channels listed below are provided with integral galvanised steel protective edge rails. For enhanced durability these rails are manufactured from UltraSTEEL™, a unique material that has improved strength over plain steel.

The added benefit of UltraSTEEL™ is that its greater surface area improves the bond between rail and adjacent material where a sealed system is required.

For the ACO MultiDrain™ M100D range of gratings to suit these channels please refer to page 10 and 11.

### Constant and sloping depth channels with UltraSTEEL™ galvanised edge rails

Product code	Description	Length (mm)	Width overall (mm)	Depth overall (mm)	Invert depth (mm)	Invert Type	Weight (kg)
23000	M100D No. 0.0*	1000	135	150	130	1/3	13.2
23050	M100D No. 0.1J*	500	135	150	130	1/3	7.6
23001	M100D No. 1	1000	135	150/155	130/135	2	13.5
23002	M100D No. 2	1000	135	155/160	135/140	2	13.8
23003	M100D No. 3	1000	135	160/165	140/145	2	14.1
23004	M100D No. 4	1000	135	165/170	145/150	2	14.4
23005	M100D No. 5	1000	135	170/175	150/155	2	14.7
23006	M100D No. 6	1000	135	175/180	155/160	2	15.0
23007	M100D No. 7	1000	135	180/185	160/165	2	15.3
23008	M100D No. 8	1000	135	185/190	165/170	2	15.6
23009	M100D No. 9	1000	135	190/195	170/175	2	15.9
23010	M100D No.10	1000	135	195/200	175/180	2	16.2
23100	M100D No.10.0*	1000	135	200	180	1/3	16.2
23101	M100D No.10.1J*	500	135	200	180	1/3	9.2
23011	M100D No.11	1000	135	200/205	180/185	2	16.5
23012	M100D No.12	1000	135	205/210	185/190	2	16.8
23013	M100D No.13	1000	135	210/215	190/195	2	17.1
23014	M100D No.14	1000	135	215/220	195/200	2	17.4
23015	M100D No.15	1000	135	220/225	200/205	2	17.7
23016	M100D No.16	1000	135	225/230	205/210	2	18.0
23017	M100D No.17	1000	135	230/235	210/215	2	18.3
23018	M100D No.18	1000	135	235/240	215/220	2	18.6
23019	M100D No.19	1000	135	240/245	220/225	2	18.9
23020	M100D No.20	1000	135	245/250	225/230	2	19.2
23200	M100D No.20.0*	1000	135	250	230	1/3	19.3
23201	M100D No.20.1J*	500	135	250	230	1/3	10.8
23300	M100D No.30.0*	1000	135	300	280	1/3	22.4
23301	M100D No.30.1J*	500	135	300	280	1/3	12.5

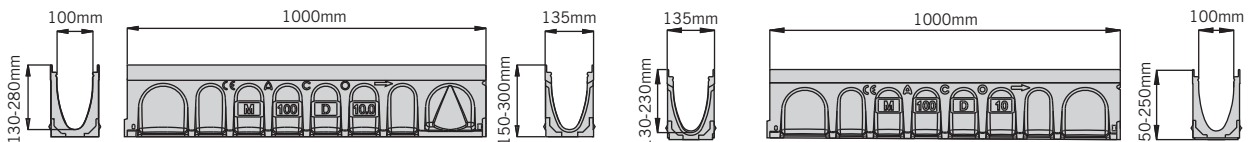

M100D 1m sloping depth channel

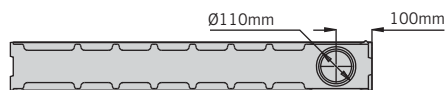

M100D 1m constant depth channel

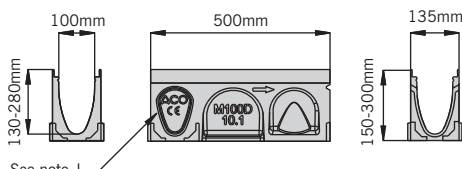

M100D 0.5m constant depth channel

**Note:** The constant depth channels have an improved knockout feature, see page 35 for more information.

\* Indicates channels supplied with a preformed  $\varnothing 110\text{mm}$  knockout for vertical outlet.

J Indicates side knockout for 90° channel connection. Knockout on both sides of the channel.

## Shallow depth channels with UltraSTEEL™ galvanised edge rails

Product code	Description	Length (mm)	Width overall (mm)	Depth overall (mm)	Invert depth (mm)	Invert Type	Weight (kg)
23075	M100D No. 075	1000	135	75	55	1	9.2
23076	M100D No. 075V	1000	135	75*	55	1	8.85
23110	M100D No. 0100	1000	135	100	80	1	11
23111	M100D No. 0100V	1000	135	100*	80	1	11

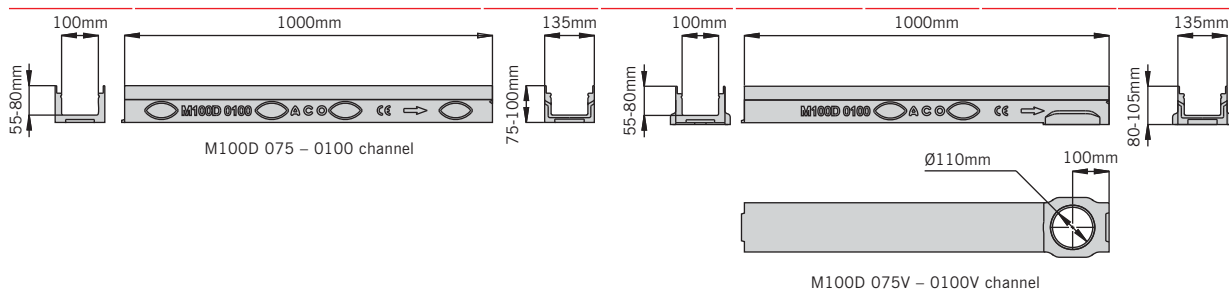

Note: V Indicates channel with cast in TPE triple lipped seals for water tight connection. See page 35 for further information.  
\*075V and 0100V channels have a depth overall around the outlet of 80mm (075V) and 105 (0100V).

## Multifunctional endcap (closing/inlet/outlet)

Product code	Description	Length (mm)	Width overall (mm)	Depth overall (mm)	Spigot length (mm)	Invert Type	Weight (kg)
23404	M100D No.306 universal endcap	-	135	75/300	50	-	0.16

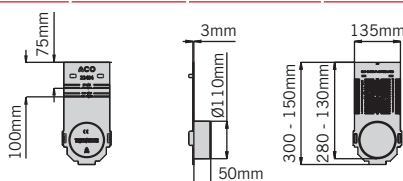

The universal end cap can be cut down to suit all M100D channels. See page 36 for further information.

## Step Connector

Product code	Description	Length (mm)	Width overall (mm)	Stepped depth (mm)	Invert depth (mm)	Invert Type	Weight (kg)
12601	M100D No.123 50mm step connector	100	75	50	-	-	0.4

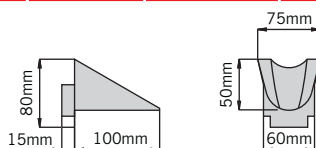

Note: For information on the step connector functionality see page 36.

## Sump unit with UltraSTEEL™ galvanised edge rails

Product code	Description	Length (mm)	Width overall (mm)	Depth overall (mm)	Invert depth (mm)	Invert Type	Weight (kg)
23410	M100D universal sump with plastic silt bucket	500	135	635	615	-	32.8

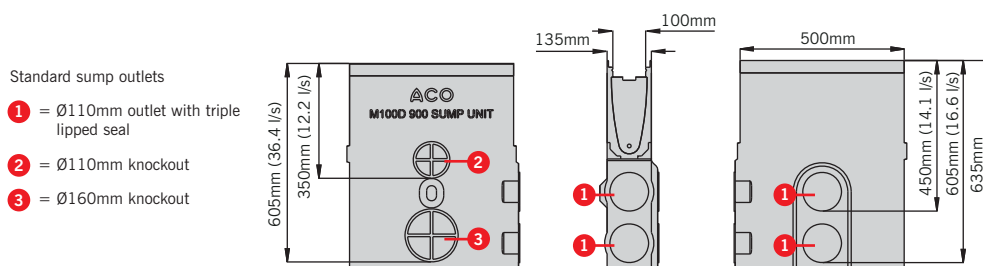

Note: Drawing shows flow through un-trapped unions. For information on the sump unit functionality see page 37.

# ACO MultiDrain™ MD System

## Technical Data

### Foul air traps

Product code	Description	Length (mm)	Width overall (mm)	Depth overall (mm)	Invert depth (mm)	Invert Type	Weight (kg)
0056	820 Drain union PVC-U Ø110mm (max 12.2 / 16.6 l/s)	100	110	-	350-605	-	0.14
0058	822 Drain union PVC-U Ø160mm (max 36.4 l/s)	100	160	-	605	-	0.53
2640	920 foul air trap PVC-U Ø110mm (max 12.2 l/s)	-	110	-	360	-	0.5
2638	922 foul air trap PVC-U Ø160mm (max 25 l/s)	-	160	-	340	-	1.9
7931	940 Roddable foul air trap MDPE Ø110mm (max 14 l/s)	-	110	-	450	-	0.56
7932	950 Roddable foul air trap MDPE Ø160mm (max 29 l/s)	-	160	-	400	-	0.83

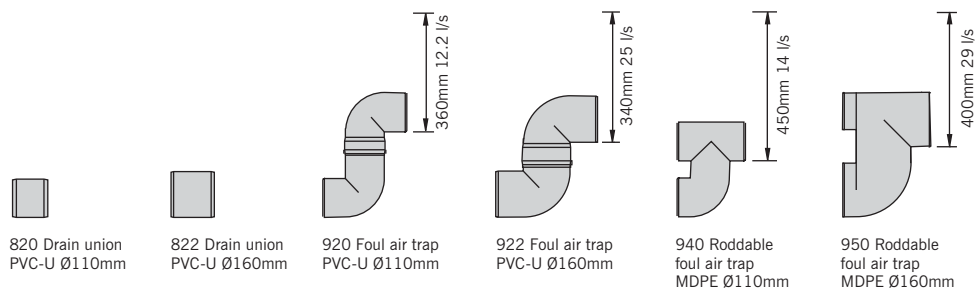

### Universal Gully and accessories

Product code	Description	Length (mm)	Width overall (mm)	Depth overall (mm)	Invert depth (mm)	Invert Type	Weight (kg)
33601	Gully assembly and bucket 601	440	440	1315	870	-	78.8
33602	Gully assembly no bucket 602	440	440	1315	870	-	77.4
33607	Gully top assembly 607	440	440	650	-	-	73.1
33605	Base unit 605	Ø375	Ø375	750	310	-	4.3
33603	Intermediate unit 603	440	440	515	-	-	5.1
33604	Grating and frame 604	440	440	100	-	-	69.5
7060	Connector 615	500	Ø500	40	-	-	7
33606	Bucket polythene 606	Ø275	Ø275	250	-	-	1.4

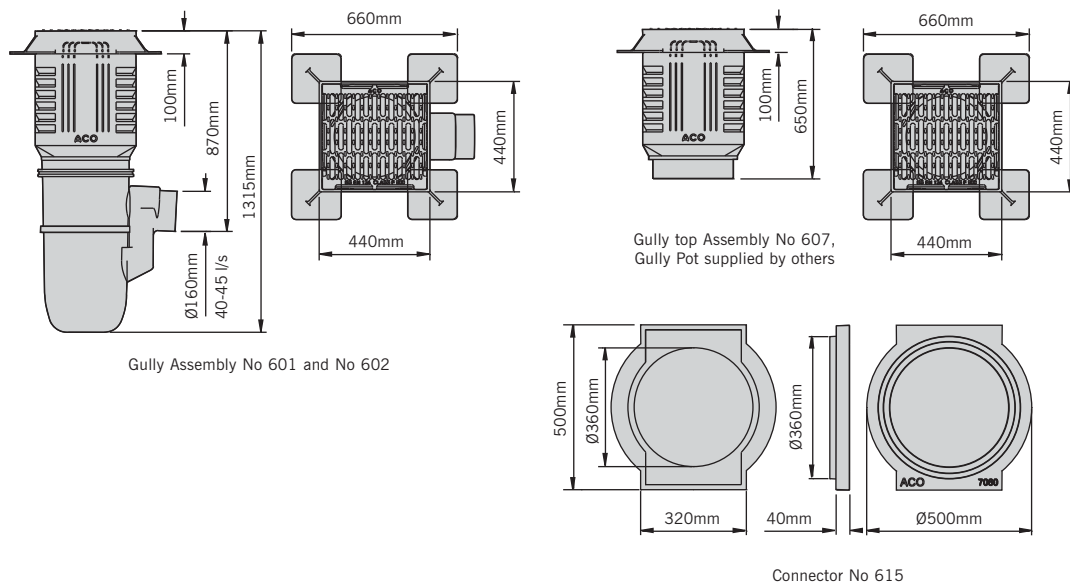

Note: Plain U-PVC 150mm – 160mm Supersleeve adaptor supplied with 601, 602 and 605 assembly.  
Grating slot width 19mm. For information on the universal gully functionality see page 37.



## ACO Drainlock™ Gratings

### Grating selection

All channels within the ACO MultiDrain™ MD range are certified to BS EN 1433: 2002 Load Class D 400. The system has a wide range of gratings suitable for use in a variety of applications from Load Class A15 to D 400. Refer to the chart on page 3 for load classes and typical applications. Please note when selecting a grating careful consideration should be given to the application requirement. Each grating has a certified load class which, once installed with the channel, determines the system's load class.

### ACO Drainlock™

Fitted as standard to ACO MultiDrain™ MD gratings, this fast locking device removes the need for bolts and bars and improves the channels hydraulic capacity. The Drainlock™ mechanism simply clips into the channel edge rail for rapid installation. An installation guide is shown opposite.

### Anti-shunt mechanism

A selection of the ACO Drainlock™ gratings are fitted with an anti-shunt mechanism that restricts unwanted grating movement when installed. This feature improves the durability and the aesthetics of the system. See figure 2 for details

### Security Locking

In areas such as schools and prisons, where unwanted grating removal needs to be restricted, a security locking can be used in conjunction with the following gratings; on ACO M100D, 12680 and 23405 on ACO M150D, 23161 and on ACO M200D 23221. The system is fitted to the gratings by two M6 security screws and clamps the grating in place preventing removal. See figure 5 & 6 for details. Security locking key for installation and removal supplied separately.

### Fitting the grating



To install, align the grating onto the channel



Align anti-shunt detail with recess



Push or stand on the grating until it clicks into place



ACO Drainlock™ locking mechanism fastens into channel

### Security locking



Fix the M6 security screws and clamp the grating as shown.



Place grating into the channel and tighten the fixing using the security locking key

### Removal of grating



Insert tool as shown.  
Drainlock lifting tool available part no 1367



Pull upwards to unlock grating

# ACO MultiDrain™ MD System

## Technical Data

Gratings for use with ACO MultiDrain™ M100D channels with UltraSTEEL™ galvanised edge rails.



### Gratings for Load Class A 15 applications

Product code	Description	Length (mm)	Width overall (mm)	Depth overall (mm)	Slot width / hole dia (mm)	Intake area mm <sup>2</sup> /m	Anti-shunt feature	Weight (kg)
12610	Slotted galvanised steel 400DL	1000	123	21	10	31200	n/a	2.2
12611	Slotted galvanised steel 402DL	500	123	21	10	31200	n/a	1
12666	Perforated galvanised steel 12666DL	1000	123	21	6	17800	n/a	2.2
12667	Perforated galvanised steel 12667DL	500	123	21	6	17800	n/a	1



400DL / 402DL  
Slotted galvanised steel



12666DL / 12667DL  
Perforated galvanised steel



### Gratings for Load Class C 250 applications

Product code	Description	Length (mm)	Width overall (mm)	Depth overall (mm)	Slot width / hole dia (mm)	Intake area mm <sup>2</sup> /m	Anti-shunt feature	Weight (kg)
12680	Heelguard™ composite - black 522DL 	500	123	21	8	14250	Yes	1.2
12673	Intercept ductile iron 507DL	500	123	21	31 x 12	43000	Yes	3.5
12614	Slotted galvanised steel 423DL	1000	123	21	10	31200	n/a	4.3
12615	Slotted galvanised steel 424DL	500	123	21	10	31200	n/a	2.2
12656	Perforated galvanised steel 12656DL	1000	123	21	6	17800	n/a	2.2
12657	Perforated galvanised steel 12657DL	500	123	21	6	17800	n/a	1
12618	Mesh galvanised steel 410DL	1000	123	21	25 x 12	88000	Yes	3.1
12619	Mesh galvanised steel 412DL	500	123	21	25 x 12	88000	Yes	1.5



522DL  
Heelguard™ composite



507DL  
Intercept ductile iron



423DL / 424DL  
Slotted galvanised steel



12656DL / 12657DL  
Perforated galvanised steel

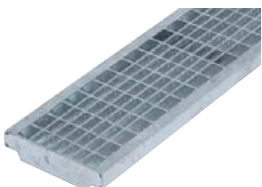

410DL / 412DL  
Mesh galvanised steel

 Indicates security locking available.



### Gratings for Load Class C 250 / D 400 applications

Product code	Description	Length (mm)	Width overall (mm)	Depth overall (mm)	Slot width / hole dia (mm)	Intake area mm <sup>2</sup> /m	Anti-shunt feature	Weight (kg)
23405	Heelguard™ ductile iron 23405DL <b>6</b>	500	123	21	8	25400	Yes	4.2
23406	Ductile iron solid cover 23406DL	500	123	21	n/a	n/a	Yes	4.5
23408	Slotted ductile iron 23408DL	500	123	21	12	36200	Yes	3.8



23405DL  
Heelguard™ ductile iron



23406DL  
Ductile iron solid cover



23408DL  
Slotted ductile iron

### Grating accessories

Product code	Description	Length (mm)	Width overall (mm)	Depth overall (mm)	Invert depth (mm)	Invert Type	Weight (kg)
23415	Drainlock security locking assembly	n/a	n/a	n/a	n/a	n/a	0.1
23416	Drainlock security key	n/a	n/a	n/a	n/a	n/a	0.01
1367	Drainlock grating lifting tool 835	n/a	n/a	n/a	n/a	n/a	0.1

**6** Indicates security locking available.

# ACO MultiDrain™ MD System

## Technical Data

### ACO MultiDrain™ M100DS channels with stainless steel edge rails

ACO MultiDrain™ M100DS channels are manufactured from polymer concrete, a tough and robust material which provides high chemical resistance. For improved aesthetics and performance, the channels listed below are provided with integral stainless steel (Grade 304) protective edge rails.

These channels are available in constant depth and shallow depth units.

For the ACO MultiDrain™ M100DS range of gratings to suit these channels please refer to page 14.

#### Constant depth channels with stainless steel edge rails

Product code	Description	Length (mm)	Width overall (mm)	Depth overall (mm)	Invert depth (mm)	Invert Type	Weight (kg)
24000	M100DS No. 0.0*	1000	135	150	130	1/3	14.9
24050	M100DS No. 0.1J*	500	135	150	130	1/3	8.6
24100	M100DS No.10.0*	1000	135	200	180	1/3	17.9
24101	M100DS No.10.1J*	500	135	200	180	1/3	10.2
24200	M100DS No.20.0*	1000	135	250	230	1/3	21
24201	M100DS No.20.1J*	500	135	250	230	1/3	11.8

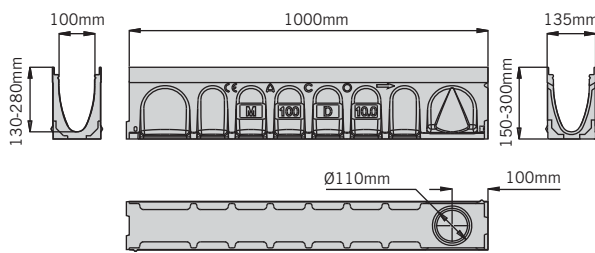

M100DS 075 - 0100 channel

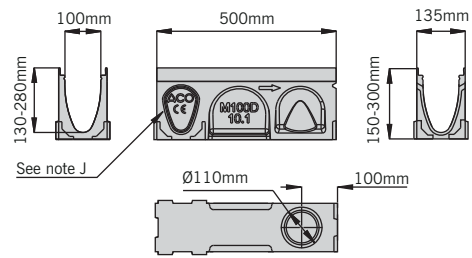

M100DS 0.5m constant depth channel

#### Shallow channels with stainless steel edge rails

Product code	Description	Length (mm)	Width overall (mm)	Depth overall (mm)	Invert depth (mm)	Invert Type	Weight (kg)
24075	M100DS No. 075	1000	135	75	55	1	10.9
24076	M100DS No. 075V	1000	135	75†	55	1	10.55
24110	M100DS No. 0100	1000	135	100	80	1	12.7
24111	M100DS No. 0100V	1000	135	100†	80	1	12.4

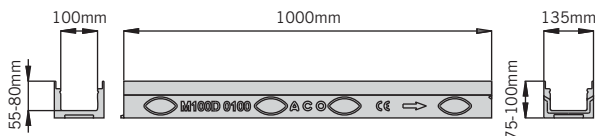

M100DS 075V - 0100V channel

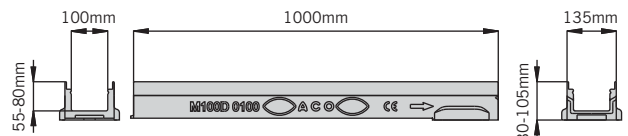

M100DS 075V - 100V channel

Note: The constant depth channels have an improved knockout feature, see page 35 for more information.

\* Indicates channels supplied with a preformed Ø110mm knockout for vertical outlet

J Indicates side knockout for 90° channel connection. Knockout on both sides of the channel.

V Indicates channel with cast in TPE triple lipped seals for water tight connection. See page 35 for further information.

† 075V and 0100V channels have a depth overall around the outlet of 80mm (075V) and 105 (0100V).



### Multifunctional endcap (closing/inlet/outlet)

Product code	Description	Length (mm)	Width overall (mm)	Depth overall (mm)	Spigot length (mm)	Invert Type	Weight (kg)
23404	M100D No.306 universal endcap	-	135	75/300	50	-	0.16

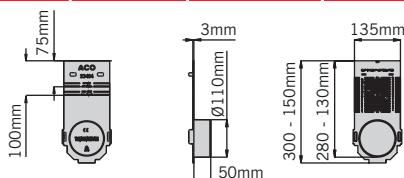

The universal end cap can be cut down to suit all M100DS channels. See page 36 for further information.

### Step Connector

Product code	Description	Length (mm)	Width overall (mm)	Stepped depth (mm)	Invert depth (mm)	Invert Type	Weight (kg)
12601	M100D No.123 50mm step connector	100	75	50	-	-	0.4

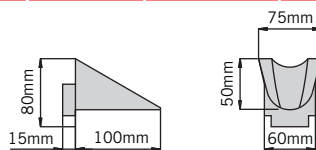

Note: For information on the step connector functionality see page 36.

### Sump unit with stainless steel edge rails

Product code	Description	Length (mm)	Width overall (mm)	Depth overall (mm)	Invert depth (mm)	Invert Type	Weight (kg)
24410	M100DS universal sump with plastic silt bucket	500	135	635	615	-	33.9

Standard sump outlets

- 1 = Ø110mm outlet with triple lipped seal
- 2 = Ø110mm knockout
- 3 = Ø160mm knockout

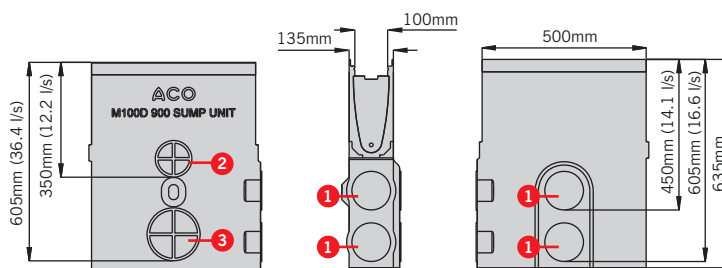

Note: Drawing shows flow through un-trapped unions. For information on the sump unit functionality see page 37.

Note: For ACO Universal Gully and foul air trap details please refer to page 8.

# ACO MultiDrain™ MD System

## Technical Data

Gratings for use with ACO MultiDrain™ M100DS channels with stainless steel edge rails

### Gratings for Load Class A 15 applications



Product code	Description	Length (mm)	Width overall (mm)	Depth overall (mm)	Slot width / hole dia (mm)	Intake area mm <sup>2</sup> /m	Anti-shunt feature	Weight (kg)
12640	Slotted stainless steel 460DL	1000	123	21	10	31200	n/a	2
12641	Slotted stainless steel 461DL	500	123	21	10	31200	n/a	1.1
12664	Perforated stainless steel 12664DL	1000	123	21	6	17800	n/a	2.9
12665	Perforated stainless steel 12665DL	500	123	21	6	17800	n/a	1.4



460DL / 461DL  
Slotted stainless steel



12664DL / 12665DL  
Perforated stainless steel

### Gratings for Load Class C 250 applications



Product code	Description	Length (mm)	Width overall (mm)	Depth overall (mm)	Slot width / hole dia (mm)	Intake area mm <sup>2</sup> /m	Anti-shunt feature	Weight (kg)
12644	Slotted stainless steel 470DL	1000	123	21	10	32100	n/a	2.6
12645	Slotted stainless steel 471DL	500	123	21	10	32100	n/a	1.4
12654	Perforated stainless steel 12654DL	1000	123	21	6	17800	n/a	4.8
12655	Perforated stainless steel 12655DL	500	123	21	6	17800	n/a	2.3
12648	Mesh stainless steel 430DL	1000	123	21	25 x 12	88000	Yes	4.6
12649	Mesh stainless steel 431DL	500	123	21	25 x 12	88000	Yes	2



470DL / 471DL  
Slotted stainless steel



12654DL / 12655DL  
Perforated stainless steel



430DL / 431DL  
Mesh stainless steel

### stainless steel grating accessories

Product code	Description	Length (mm)	Width overall (mm)	Depth overall (mm)	Invert depth (mm)	Invert Type	Weight (kg)
1367	Drainlock grating lifting tool 835	n/a	n/a	n/a	n/a	n/a	0.1



## ACO MultiDrain™ M150D channels with UltraSTEEL galvanised edge rails

ACO MultiDrain™ M150D channels are manufactured from polymer concrete, a tough and robust material which provides high chemical resistance. The channels are available in constant depth and shallow depth units.

ACO MultiDrain™ M150D channels listed below are provided with integral galvanised steel protective edge rails. For enhanced durability these rails are manufactured from UltraSTEEL™, a unique material that has improved strength over plain steel.

The added benefit of UltraSTEEL™ is that its greater surface area improves the bond between rail and adjacent material where a sealed system is required.

For the ACO MultiDrain™ M150D range of gratings to suit these channels please refer to page 17.

### Constant depth channels with UltraSTEEL™ galvanised edge rails

Product code	Description	Length (mm)	Width overall (mm)	Depth overall (mm)	Invert depth (mm)	Invert Type	Weight (kg)
23150	M150D No. 0.0*	1000	185	210	185	1/3	21.6
23153	M150D No. 0.1J*	500	185	210	185	1/3	12.7
23151	M150D No.10.0*	1000	185	260	235	1/3	25.0
23154	M150D No. 10.1J*	500	185	260	235	1/3	14.6
23152	M150D No.20.0*	1000	185	310	285	1/3	28.3
23155	M150D No. 20.1J*	500	185	310	285	1/3	16.4

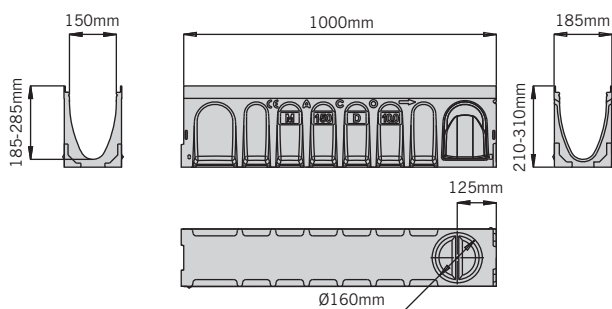

M150D 1m constant depth channel

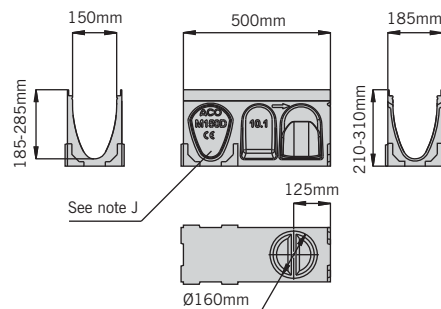

M150D 0.5m constant depth channel

### Shallow depth channels with UltraSTEEL™ galvanised edge rails

Product code	Description	Length (mm)	Width overall (mm)	Depth overall (mm)	Invert depth (mm)	Invert Type	Weight (kg)
23156	M150D No. 0100	1000	185	100	75	1	15.0
23157	M150D No. 0100V	1000	185	100	75	1	14.2

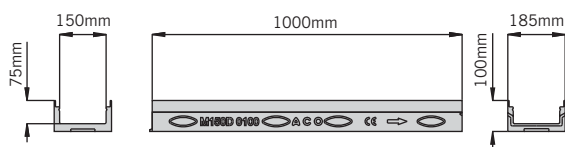

M150D 0100 channel.

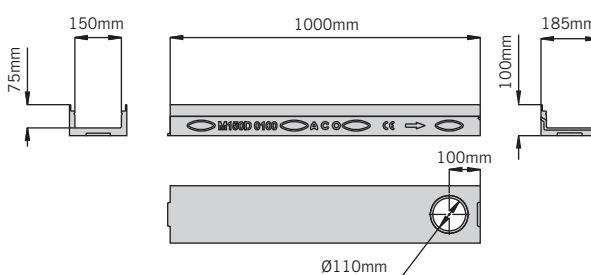

M150D 0100V channel

Note: The constant depth channels have an improved knockout feature, see page 35 for more information.

\* Indicates channels supplied with a preformed Ø160mm knockout for vertical outlet.

V Indicates channel with cast in TPE triple lipped seals for water tight connection. See page 35 for further information.

J Indicates side knockout for 90° channel connection. Knockout on both sides of the channel.

# ACO MultiDrain™ MD System

## Technical Data

### Multifunctional endcap (closing/inlet/outlet)

Product code	Description	Length (mm)	Width overall (mm)	Depth overall (mm)	Spigot length (mm)	Invert Type	Weight (kg)
23159	M150D No. 306 universal endcap	-	185	310/100	75	-	0.3

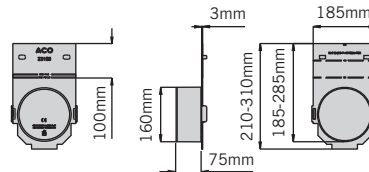

The universal end cap can be cut down to suit all M150D channels. See page 36 for further information.

### Step Connector

Product code	Description	Length (mm)	Width overall (mm)	Stepped depth (mm)	Invert depth (mm)	Invert Type	Weight (kg)
13001	M150D No.123 50mm Step connector	100	98	50	-	-	0.5

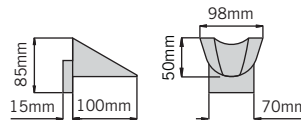

Note: For information on the step connector functionality see page 36.

### Sump unit with UltraSTEEL™ galvanised edge rails

Product code	Description	Length (mm)	Width overall (mm)	Depth overall (mm)	Invert depth (mm)	Invert Type	Weight (kg)
23158	M150D universal sump with plastic silt bucket	500	185	735	715	-	44

Standard sump outlets

- 1 = Ø110mm outlet with triple lipped seal
- 2 = Ø160mm outlet
- 3 = Ø200mm knockout

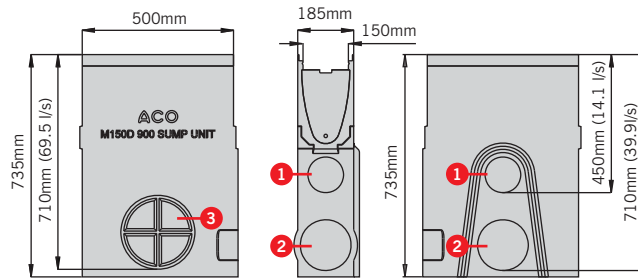

Note: Drawing shows flow through un-trapped unions. For information on the sump unit functionality see page 37.

### Foul air traps

Product code	Description	Length (mm)	Width overall (mm)	Depth overall (mm)	Invert depth (mm)	Invert Type	Weight (kg)
0056	820 Drain union PVC-U Ø110mm (max 14.1 l/s)	100	110	-	450	-	0.14
0058	822 Drain union PVC-U Ø160mm (max 39.9 l/s)	100	160	-	710	-	0.53
2723	823 Drain Union PVC-U Ø200mm (max 69.5 l/s)	200	200	-	710	-	0.6
2638	922 Foul air trap PVC-U Ø160mm (max 31 l/s)	-	160	-	445	-	1.9
7932	950 Roddable foul air trap MDPE Ø160mm (max 32 l/s)	-	160	-	505	-	0.83

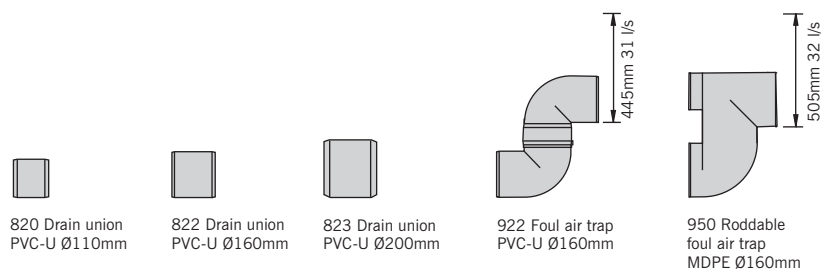

Note: For ACO Universal Gully details please refer to page 8



## Gratings for use with ACO MultiDrain™ M150D channels with UltraSTEEL galvanised edge rail



### Gratings for Load Class C 250 applications

Product code	Description	Length (mm)	Width overall (mm)	Depth overall (mm)	Slot width /hole dia (mm)	Intake area mm <sup>2</sup> /m	Anti-shunt feature	Weight (kg)
13073	Intercept ductile iron 13073DL	500	173	21	12 x 30	59500	Yes	5.3
13018	Mesh galvanised steel 13018DL	1000	173	30	23 x 17	115100	Yes	7.4
13019	Mesh galvanised steel 13019DL	500	173	30	23 x 17	115100	Yes	3.7

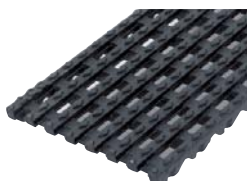

13073DL  
Intercept ductile iron



13018DL / 13019DL  
Mesh galvanised steel



### Gratings for Load Class C 250 / D 400 applications

Product code	Description	Length (mm)	Width overall (mm)	Depth overall (mm)	Slot width /hole dia (mm)	Intake area mm <sup>2</sup> /m	Anti-shunt feature	Weight (kg)
23161	Heelguard™ ductile iron 23161DL <sup>6</sup>	500	173	28	8	40000	Yes	6.8
23160	Ductile iron solid cover 23160DL	500	173	28	n/a	n/a	Yes	6.7
23164	Slotted ductile iron 23164DL	500	173	28	12	57664	Yes	6.4



23161DL  
Heelguard™ ductile iron



23160DL  
Ductile iron solid cover



23164DL  
Slotted ductile iron

### Grating accessories

Product code	Description	Length (mm)	Width overall (mm)	Depth overall (mm)	Invert depth (mm)	Invert Type	Weight (kg)
23165	Drainlock security locking assembly	n/a	n/a	n/a	n/a	n/a	0.1
23416	Drainlock security key	n/a	n/a	n/a	n/a	n/a	0.01
1367	Drainlock grating lifting tool 835	n/a	n/a	n/a	n/a	n/a	0.1

<sup>6</sup> Indicates security locking available.

# ACO MultiDrain™ MD System

## Technical Data

### ACO MultiDrain™ M150DS channels with stainless steel edge rails

ACO MultiDrain™ M150DS channels are manufactured from polymer concrete, a tough and robust material which provides high chemical resistance. For improved aesthetics and performance, the channels listed below are provided with integral stainless steel (Grade 304) protective edge rails.

These channels are available in constant depth and shallow depth units.

For the ACO MultiDrain™ M150DS range of gratings to suit these channels please refer to page 20.

#### Constant depth channels with stainless steel edge rails

Product code	Description	Length (mm)	Width overall (mm)	Depth overall (mm)	Invert depth (mm)	Invert Type	Weight (kg)
24150	M150DS No. 0.0*	1000	185	210	185	1/3	23.3
24153	M150DS No. 0.1J*	500	185	210	185	1/3	13.7
24151	M150DS No. 10.0*	1000	185	260	235	1/3	26.7
24154	M150DS No. 10.1J*	500	185	260	235	1/3	15.6
24152	M150DS No. 20.0*	1000	185	310	285	1/3	30.0
24155	M150DS No. 20.1J*	500	185	310	285	1/3	17.4

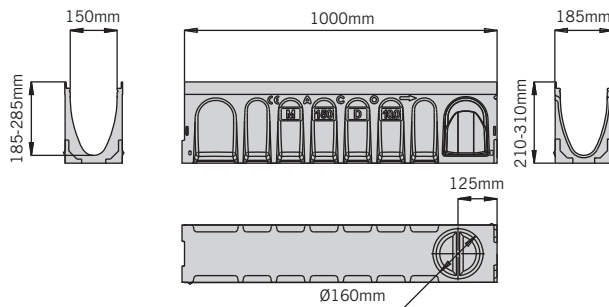

M150DS 1m constant depth channel

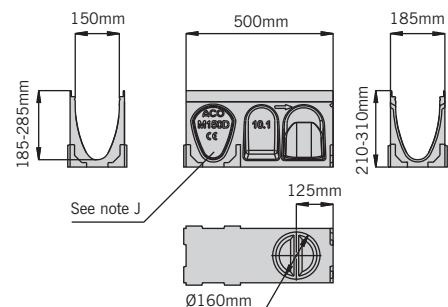

M150DS 0.5m constant depth channel

#### Shallow depth channels with stainless steel edge rails

Product code	Description	Length (mm)	Width overall (mm)	Depth overall (mm)	Invert depth (mm)	Invert Type	Weight (kg)
24156	M150DS No. 0100	1000	185	100	75	1	16.7
24157	M150DS No. 0100V	1000	185	100	75	1	15.9

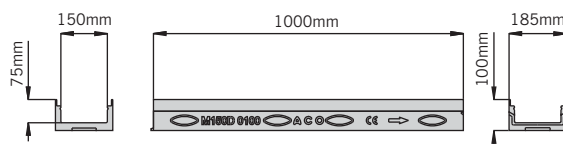

M150DS 0100 channel.

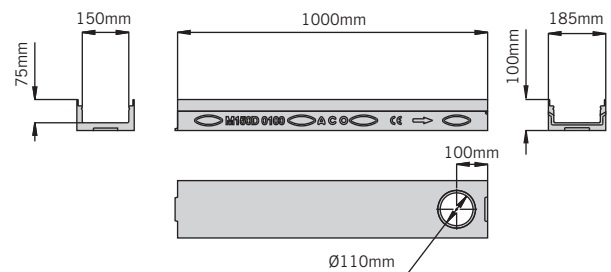

M150DS 0100V channel

Note: The constant depth channels have an improved knockout feature, see page 35 for more information.

\* Indicates channels supplied with a preformed Ø160mm knockout for vertical outlet.

J Indicates side knockout for 90° channel connection. Knockout on both sides of the channel.

V Indicates channel with cast in TPE triple lipped seals for water tight connection. See page 35 for further information.

### Multifunctional endcap (closing/inlet/outlet)

Product code	Description	Length (mm)	Width overall (mm)	Depth overall (mm)	Spigot length (mm)	Invert Type	Weight (kg)
23159	M150D No. 306 universal endcap	-	185	310/100	75	-	0.3

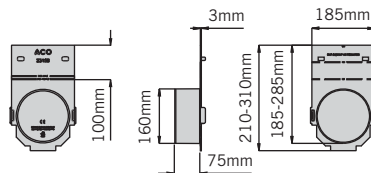

The universal end cap can be cut down to suit all M150DS channels. See page 36 for further information.

### Step Connector

Product code	Description	Length (mm)	Width overall (mm)	Stepped depth (mm)	Invert depth (mm)	Invert Type	Weight (kg)
13001	M150D No.123 50mm Step connector	100	98	50	-	-	0.5

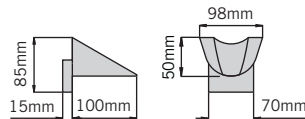

Note: For information on the step connector functionality see page 36.

### Sump unit with stainless steel edge rails

Product code	Description	Length (mm)	Width overall (mm)	Depth overall (mm)	Invert depth (mm)	Invert Type	Weight (kg)
24158	M150DS universal sump with plastic silt bucket	500	185	735	715	-	45

Standard sump outlets

- ① = Ø110mm outlet with triple lipped seal
- ② = Ø160mm outlet
- ③ = Ø200mm knockout

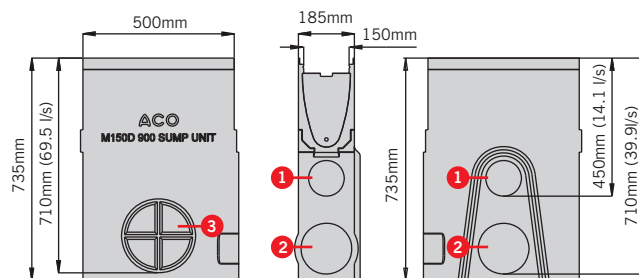

Note: Drawing shows flow through un-trapped unions. For information on the sump unit functionality see page 37.

Note: For ACO Universal Gully details please refer to page 8. For Foul air trap details please refer to page 16.

# ACO MultiDrain™ MD System

## Technical Data

Gratings for use with ACO MultiDrain™ M150DS channels with stainless steel edge rails



### Grating for Load Class C 250 applications

Product code	Description	Length (mm)	Width overall (mm)	Depth overall (mm)	Slot width /hole Ø (mm)	Intake area mm <sup>2</sup> /m	Anti-shunt feature	Weight (kg)
13048	Mesh stainless steel 13048DL	1000	173	30	23 x 17	115100	Yes	7.4
13049	Mesh stainless steel 13049DL	500	173	31	23 x 17	115100	Yes	3.7



13048DL / 13049DL  
Mesh stainless steel

### Grating accessories

Product code	Description	Length (mm)	Width overall (mm)	Depth overall (mm)	Invert depth (mm)	Invert Type	Weight (kg)
1367	Drainlock grating lifting tool 835	n/a	n/a	n/a	n/a	n/a	0.1

## ACO MultiDrain™ M200D channels with UltraSTEEL galvanised edge rails

ACO MultiDrain™ M200D channels are manufactured from polymer concrete, a tough and robust material which provides high chemical resistance. The channels are available in constant depth and shallow depth units.

ACO MultiDrain™ M200D channels listed below are provided with integral galvanised steel protective edge rails. For enhanced durability these rails are manufactured from UltraSTEEL™, a unique material that has improved strength over plain steel.

The added benefit of UltraSTEEL™ is that its greater surface area improves the bond between rail and adjacent material where a sealed system is required.

For the ACO MultiDrain™ M200D range of gratings to suit these channels please refer to page 23.

### Constant depth channels with UltraSTEEL™ galvanised edge rails

Product code	Description	Length (mm)	Width overall (mm)	Depth overall (mm)	Invert depth (mm)	Invert Type	Weight (kg)
23210	M200D No. 0.0*	1000	235	265	240	1/3	30.6
23213	M200D No. 0.1J*	500	235	265	240	1/3	17.9
23211	M200D No.10.0*	1000	235	315	290	1/3	34.2
23214	M200D No. 10.1J*	500	235	315	290	1/3	19.9
23212	M200D No.20.0*	1000	235	365	340	1/3	37.7
23215	M200D No. 20.1J*	500	235	365	340	1/3	21.9

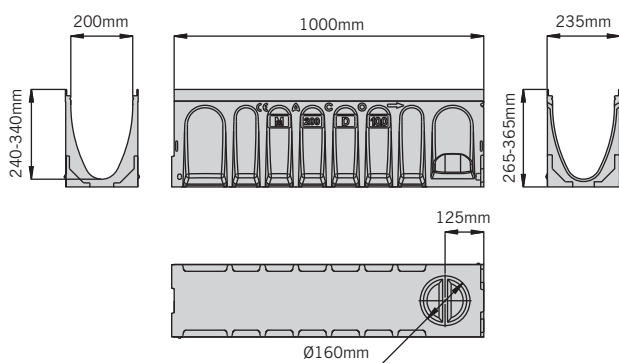

M200D 1m constant depth channel

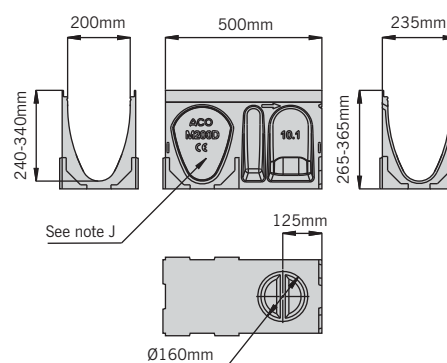

M200D 0.5m constant depth channel

### Shallow depth channels with UltraSTEEL™ galvanised edge rails

Product code	Description	Length (mm)	Width overall (mm)	Depth overall (mm)	Invert depth (mm)	Invert Type	Weight (kg)
23216	M200D No. 0100	1000	235	100	75	1	17.5
23217	M200D No. 0100V	1000	235	100	75	1	17.0

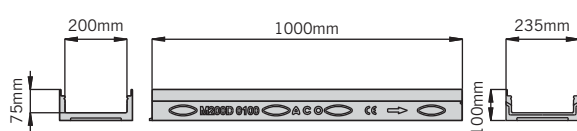

M200D 0100 channel

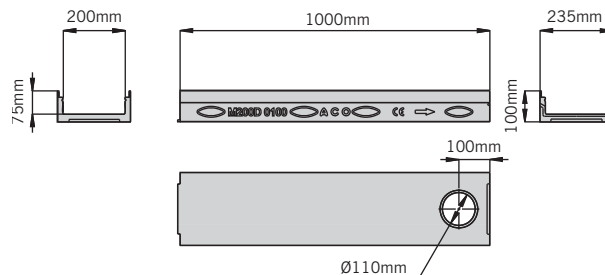

M200D 0100V channel

**Note:** The constant depth channels have an improved knockout feature, see page 35 for more information.

\* Indicates channels supplied with a preformed Ø160mm knockout for vertical outlet

J Indicates side knockout for 90° channel connection. Knockout on both sides of the channel.

V Indicates channel with cast in TPE triple lipped seals for water tight connection. See page 35 for further information.

# ACO MultiDrain™ MD System

## Technical Data

### Multifunctional endcap (closing/inlet/outlet)

Product code	Description	Length (mm)	Width overall (mm)	Depth overall (mm)	Spigot length (mm)	Invert Type	Weight (kg)
23219	M200D No. 306 universal endcap	-	235	365/100	75	-	0.4

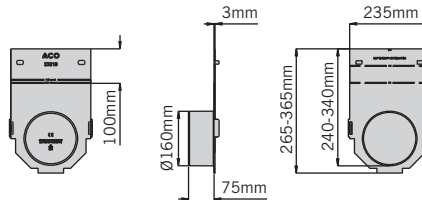

The universal end cap can be cut down to suit all M200D channels. See page 36 for further information.

### Step Connector

Product code	Description	Length (mm)	Width overall (mm)	Stepped depth (mm)	Invert depth (mm)	Invert Type	Weight (kg)
13401	M200D No.123 50mm Step connector	100	120	50	-	-	0.6

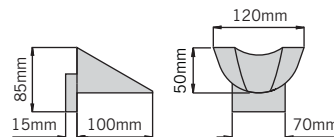

Note: For information on the step connector functionality see page 36.

### Sump unit with UltraSTEEL™ galvanised edge rails

Product code	Description	Length (mm)	Width overall (mm)	Depth overall (mm)	Invert depth (mm)	Invert Type	Weight (kg)
23218	M200D universal sump with plastic silt bucket	500	235	790	765	-	47

Standard sump outlets

- 1 = Ø110mm outlet with triple lipped seal
- 2 = Ø160mm outlet
- 3 = Ø200mm knockout

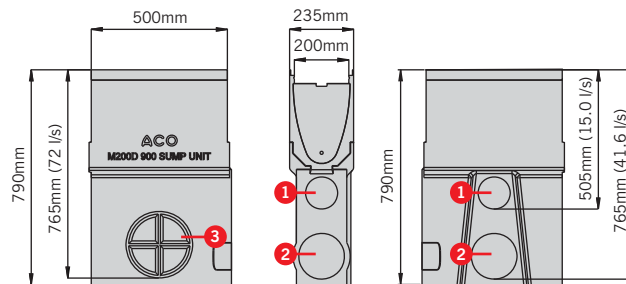

Note: Drawing shows flow through un-trapped unions. For information on the sump unit functionality see page 37.

### Foul air traps

Product code	Description	Length (mm)	Width overall (mm)	Depth overall (mm)	Invert depth (mm)	Invert Type	Weight (kg)
0056	820 Drain union PVC-U Ø110mm (max 15.0 l/s)	100	110	-	505	-	0.14
0058	822 Drain union PVC-U Ø160mm (max 41.6 l/s)	100	160	-	765	-	0.53
2723	823 Drain Union PVC-U Ø200mm (max 72 l/s)	200	200	-	765	-	0.6
2638	922 Foul air trap PVC-U Ø160mm (max 32 l/s)	-	160	-	500	-	1.9
7932	950 Roddable foul air trap MDPE Ø160mm (max 34 l/s)	-	160	-	560	-	0.83

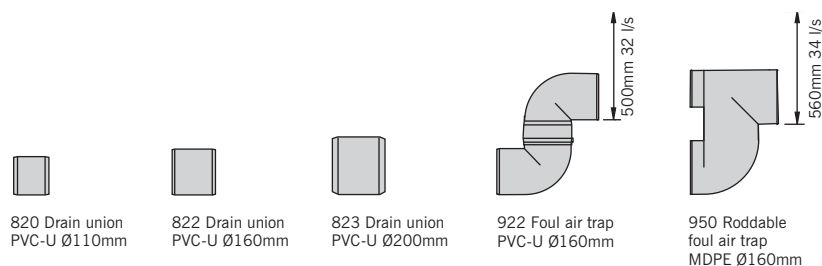

Note: For ACO Universal Gully details please refer to page 8

## Gratings for use with ACO MultiDrain™ M200D channels with UltraSTEEL™ galvanised edge rails



### Gratings for Load Class C 250 applications

Product code	Description	Length (mm)	Width overall (mm)	Depth overall (mm)	Slot width /hole dia (mm)	Intake area (mm²/m)	Anti-shunt feature	Weight (kg)
13473	Intercept ductile iron 13473DL	500	223	35	30.5 x 4	90500	Yes	7.5
13418	Mesh galvanised steel 13418DL	1000	223	40	23 x 17	154100	Yes	12
13419	Mesh galvanised steel 13419DL	500	223	40	23 x 17	154100	Yes	6

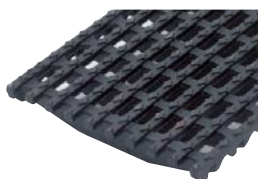

13473DL  
Intercept ductile iron



13418DL / 13419DL  
Mesh galvanised steel



### Gratings for Load Class C 250 / D 400 applications

Product code	Description	Length (mm)	Width overall (mm)	Depth overall (mm)	Slot width /hole dia (mm)	Intake area (mm²/m)	Anti-shunt feature	Weight (kg)
23221	Heelguard™ ductile iron 23221DL <b>6</b>	500	223	32	8	47300	Yes	10.3
23220	Ductile iron solid cover 23220DL	500	223	32	n/a	n/a	Yes	11
23224	Slotted ductile iron 23224DL	500	223	32	12	36200	Yes	9.8



23221DL  
Heelguard™ ductile iron



23220DL  
Ductile iron solid cover



23224DL  
Slotted ductile iron

### Grating accessories

Product code	Description	Length (mm)	Width overall (mm)	Depth overall (mm)	Invert depth (mm)	Invert Type	Weight (kg)
23225	Drainlock security locking assembly	n/a	n/a	n/a	n/a	n/a	0.1
23416	Drainlock security key	n/a	n/a	n/a	n/a	n/a	0.01
1367	Drainlock grating lifting tool 835	n/a	n/a	n/a	n/a	n/a	0.1

# ACO MultiDrain™ MD System

## Technical Data

### ACO MultiDrain™ M200DS channels with stainless steel edge rails

ACO MultiDrain™ M200DS channels are manufactured from polymer concrete, a tough and robust material which provides high chemical resistance. For improved aesthetics and performance, the channels listed below are provided with integral stainless steel (Grade 304) protective edge rails.

These channels are available in constant depth and shallow depth units.

For the ACO MultiDrain™ M200DS range of gratings to suit these channels please refer to page 26.

#### Constant depth channels with stainless steel edge rails

Product code	Description	Length (mm)	Width overall (mm)	Depth overall (mm)	Invert depth (mm)	Invert Type	Weight (kg)
24210	M200DS No. 0.0*	1000	235	265	240	1/3	32.3
24213	M200DS No. 0.1J*	500	235	265	240	1/3	18.9
24211	M200DS No. 10.0*	1000	235	315	290	1/3	35.9
24214	M200DS No. 10.1J*	500	235	315	290	1/3	20.9
24212	M200DS No. 20.0*	1000	235	365	340	1/3	39.4
24215	M200DS No. 20.1J*	500	235	365	340 <td 1/3	22.9	

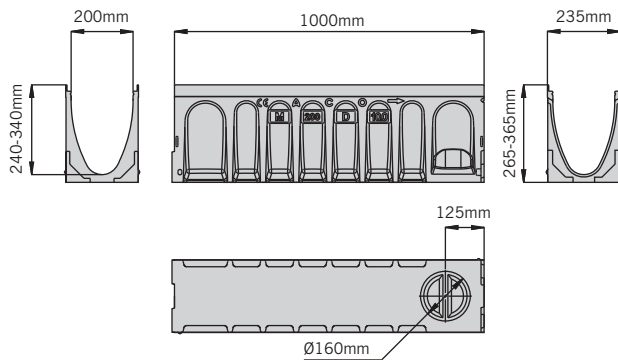

M200DS 1m constant depth channel

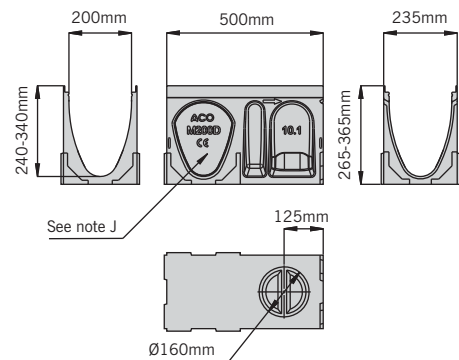

M200DS 0.5m constant depth channel

#### Shallow depth channels with stainless steel edge rails

Product code	Description	Length (mm)	Width overall (mm)	Depth overall (mm)	Invert depth (mm)	Invert Type	Weight (kg)
24216	M200DS No. 0100	1000	235	100	75	1	19.4
24217	M200DS No. 0100V	1000	235	100	75	1	18.7

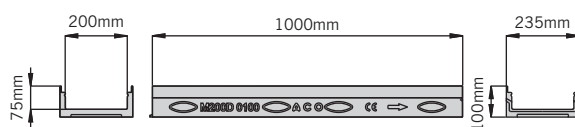

M200DS 0100 channel

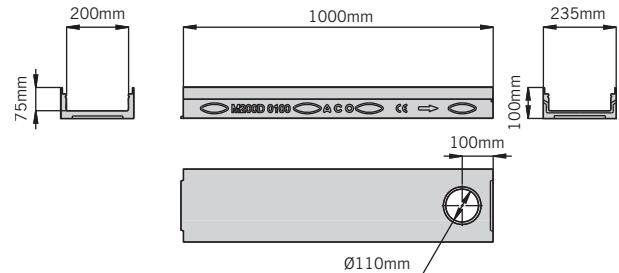

M200DS 0100V channel

**Note:** The constant depth channels have an improved knockout feature, see page 35 for more information.

\* Indicates channels supplied with a preformed Ø160mm knockout for vertical outlet

J Indicates side knockout for 90° channel connection. Knockout on both sides of the channel.

V Indicates channel with cast in TPE triple lipped seals for water tight connection. See page 35 for further information.





### Multifunctional endcap (closing/inlet/outlet)

Product code	Description	Length (mm)	Width overall (mm)	Depth overall (mm)	Spigot length (mm)	Invert Type	Weight (kg)
23219	M200D No. 306 universal endcap	-	235	365/100	75	-	0.4

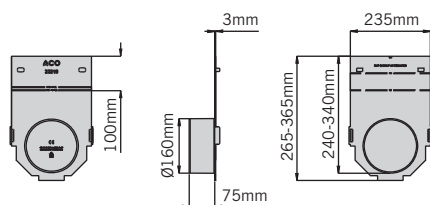

The universal end cap can be cut down to suit all M200DS channels. See page 36 for further information.

### Step Connector

Product code	Description	Length (mm)	Width overall (mm)	Stepped depth (mm)	Invert depth (mm)	Invert Type	Weight (kg)
13401	M200D No.123 50mm Step connector	100	120	50	-	-	0.6

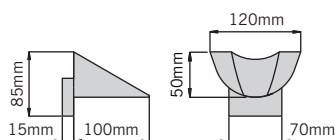

Note: For information on the step connector functionality see page 36.

### Sump unit with stainless steel edge rails

Product code	Description	Length (mm)	Width overall (mm)	Depth overall (mm)	Invert depth (mm)	Invert Type	Weight (kg)
24218	M200DS universal sump with plastic silt bucket	500	235	790	765	-	48

Standard sump outlets

- ① = Ø110mm outlet with triple lipped seal
- ② = Ø160mm outlet
- ③ = Ø200mm knockout

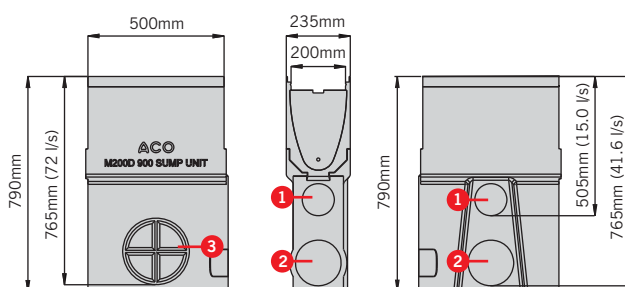

Note: Drawing shows flow through un-trapped unions. For information on the sump unit functionality see page 37.

Note: For ACO Universal Gully details please refer to page 8. For Foul air trap details please refer to page 22.

# ACO MultiDrain™ MD System

## Technical Data

Gratings for use with ACO MultiDrain™ M200DS channels with stainless steel edge rails

### Grating for Load Class C 250 applications

Product code	Description	Length (mm)	Width overall (mm)	Depth overall (mm)	Slot width /hole Ø (mm)	Intake area mm/m <sup>2</sup>	Anti-shunt feature	Weight (kg)
13448	Mesh stainless steel 13448DL	1000	223	40	23 x 17	154100	Yes	12
13449	Mesh stainless steel 13449DL	500	223	40	23 x 17	154100	Yes	6



13449DL / 13448DL  
Mesh stainless steel

### Grating accessories

Product code	Description	Length (mm)	Width overall (mm)	Depth overall (mm)	Invert depth (mm)	Invert Type	Weight (kg)
1367	Drainlock grating lifting tool 835	n/a	n/a	n/a	n/a	n/a	0.1

## Problem solving drainage solutions: Discreet slot drainage

ACO MultiDrain™ MD has a range of gratings to complement installations which require discreet slot drainage.

Designed as standard with a heelguard 10mm off set drainage inlet, ACO Brickslot is a subtle and unobtrusive grating which when combined with an ACO MultiDrain™ MD channel, can be used as a solution to complement discreet drainage applications and is ideal for use against buildings facades.

Compatible with most paving materials, the vertical sides of the grating enable pavements to be laid directly to the unit's edge. Once installed the system is totally secure and not vulnerable to vandalism or loose grates making it a suitable for applications such as schools and playgrounds where grating removal can become a hazard.

The channel and ACO Brickslot grating together provide an unobtrusive continuous slot drainage system, with high hydraulic efficiency for fast removal of surface water. ACO Brickslot gratings are available in galvanised or stainless steel and suitable for use with the 100mm and 150mm wide channels in the ACO MultiDrain™ MD range.

The system includes an ACO Brickslot access unit to ensure easy maintenance and access to the drainage system, and is also fully compatible with the range of ACO MultiDrain™ MD accessories.

The system is suitable for applications up to and including Load Class D400 (This product is not suitable for carriageways of public roads or motorways).

### Applications

- Commercial developments
- Landscaping
- Level threshold drainage
- Pedestrian precincts
- Retail developments



# ACO MultiDrain™ MD System

## Technical Data

### Discreet slot drainage

The ACO Brickslot gratings are available in two material finishes, hot-dipped galvanised and stainless steel (Grade 304), to suit the ACO MultiDrain™ 100mm and 150mm wide channels.

The off set grating has a heelguard 10mm drainage inlet, which is compatible with most types of pavements, setts, block and flags up to a maximum of 100mm depth.

The ACO Brickslot gratings are listed in the charts below and are sold separately to the channel units. For information on the ACO MultiDrain™ M100D/M100DS and M150D/M150DS channels, please refer to pages 6 to 19.

### ACO Brickslot gratings suitable for use with ACO MultiDrain™ M100D/M100DS



#### Gratings for Load Class C 250 applications

Product code	Description	Length (mm)	Width overall (mm)	Depth overall (mm)	Slot width /hole dia (mm)	Intake area (mm <sup>2</sup> /m)	Weight (kg)
23460	Brickslot galvanised steel 23460	1000	135	105	10	10000	6.6
23461	Brickslot galvanised steel 23461	500	135	105	10	10000	3.3



23460 / 23461  
Brickslot galvanised steel



#### Gratings for Load Class C 250 / D 400 applications

Product code	Description	Length (mm)	Width overall (mm)	Depth overall (mm)	Slot width /hole dia (mm)	Intake area (mm <sup>2</sup> /m)	Weight (kg)
23465	Brickslot galvanised steel 23465	1000	135	105	10	10000	6.6
23466	Brickslot galvanised steel 23466	500	135	105	10	10000	3.3
23475	Brickslot stainless steel 23475	1000	135	105	10	10000	6.6
23476	Brickslot stainless steel 23476	500	135	105	10	10000	3.3



23465 / 23466  
Brickslot galvanised steel



23475 / 23476  
Brickslot stainless steel

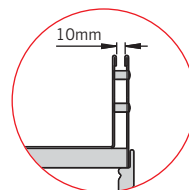

Slot detail

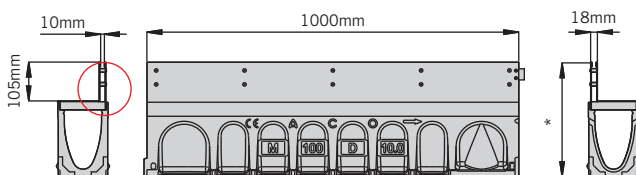

M100D 1m constant depth channel with ACO Brickslot grating

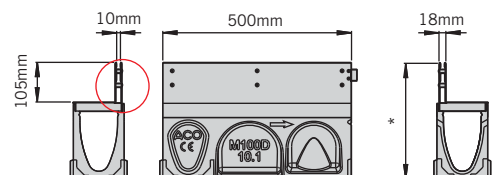

M100D 0.5m constant depth channel with ACO Brickslot grating

**Note:** To obtain the overall height (marked \*) add 105mm to the overall channel depth.  
The overall depth of each channel can be found in the channel tables in this brochure.



## ACO Brickslot gratings suitable for use with ACO MultiDrain™ M150D/M150DS



### Gratings for Load Class C 250 / D 400 applications

Product code	Description	Length (mm)	Width overall (mm)	Depth overall (mm)	Slot width /hole dia (mm)	Intake area (mm <sup>2</sup> /m)	Weight (kg)
23175	Brickslot galvanised steel 23175	1000	185	105	10	10000	7.6
23176	Brickslot galvanised steel 23176	500	185	105	10	5000	3.8
23185	Brickslot stainless steel 23185	1000	185	105	10	10000	7.6
23186	Brickslot stainless steel 23186	500	185	105	10	5000	3.8



23175 / 23176  
Brickslot galvanised steel



23185 / 23186  
Brickslot stainless steel

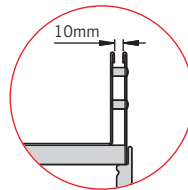

Slot detail

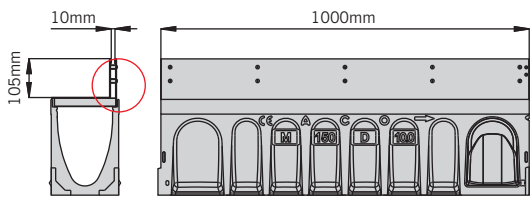

M150D 1m constant depth channel with ACO Brickslot grating

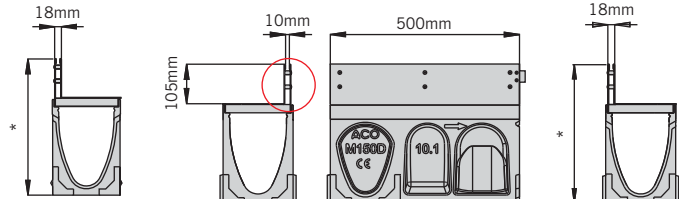

M150D 0.5m constant depth channel with ACO Brickslot grating

Note: To obtain the overall height (marked \*) add 105mm to the overall channel depth.  
The overall depth of each channel can be found in the channel tables in this brochure.



# ACO MultiDrain System

## Technical Data

The ACO Brickslot grating system has an access unit for easy maintenance and cleaning of the drainage system.

The access unit is positioned within the channel; it has a removable tray section which is lifted out of the frame by a lifting tool to gain access to the system.

The access unit is 0.5m in length and is available in the galvanised and stainless steel finishes and is suitable for use with any ACO MultiDrain™ M100D/M100DS and M150D/M150DS wide channels.

The unit has a heelguard 10mm off set drainage inlet, providing continuous aesthetic and drainage performance once installed with the drainage system.

The ACO Brickslot access units are listed in the charts below and are sold separately to the channel units. For information on the ACO MultiDrain™ M100D/M100DS and M150D/M150DS channels, please refer to pages 6 to 19.

### ACO Brickslot Access covers suitable for use with ACO MultiDrain™ M100D and M100DS channels

#### Access covers for Load Class C 250 applications



Product code	Description	Length (mm)	Width overall (mm)	Depth overall (mm)	Slot width /hole dia (mm)	Intake area (mm <sup>2</sup> /m)	Weight (kg)
23462	Brickslot access unit galvanised steel 23462	500	135	105	10	10000	6.4



23462  
Brickslot access unit  
galvanised steel.

#### Access covers for Load Class C 250 / D 400



Product code	Description	Length (mm)	Width overall (mm)	Depth overall (mm)	Slot width /hole dia (mm)	Intake area (mm <sup>2</sup> /m)	Weight (kg)
23467	Brickslot access unit galvanised steel 23467	500	135	105	10	10000	6.4
23477	Brickslot access unit stainless steel 23477	500	135	105	10	10000	6.4



23467  
Brickslot access unit  
galvanised steel.



23477  
Brickslot access unit  
stainless steel

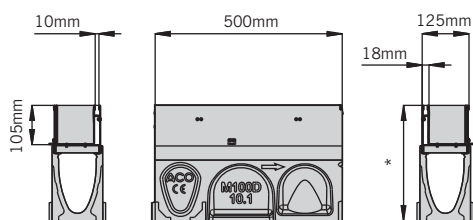

M100D 0.5m constant depth channel with  
ACO Brickslot access unit

**Note:** To obtain the overall height (marked \*) add 105mm to the overall channel depth.  
The overall depth of each channel can be found in the channel tables in this brochure.



## ACO Brickslot access units for use with ACO MultiDrain™ M150D/M150DS



### Access units for Load Class C 250 / D 400 applications

Product code	Description	Length (mm)	Width overall (mm)	Depth overall (mm)	Slot width /hole dia (mm)	Intake area (mm <sup>2</sup> /m)	Weight (kg)
23177	Brickslot access unit galvanised steel 23177	500	185	105	10	10000	6.4
23187	Brickslot access unit stainless steel 23187	500	185	105	10	10000	6.4



23177  
Brickslot access unit  
galvanised steel.

23187  
Brickslot access unit  
stainless steel

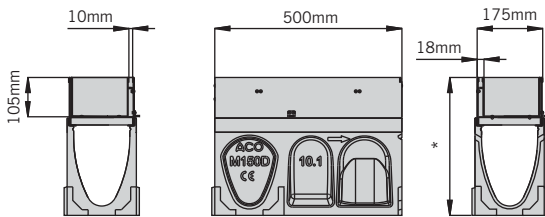

M150D 0.5m constant depth channel with  
ACO Brickslot access unit

### Removal instructions.

To remove the ACO Brickslot access unit tray, insert the lifting tools as shown in figure 1. Then lift the tray vertically from the frame (figure 2). Details on the lifting tools can be found on page 11.



Figure 1



Figure 2

**Note:** To obtain the overall height (marked \*) add 105mm to the overall channel depth.  
The overall depth of each channel can be found in the channel tables in this brochure.

# Channel footpath drainage

Specifically for use where roof drainage from down pipes is required to cross the footpath into the road gutter, ACO MultiDrain™ M100D/M100DS systems has a range of accessories to construct a footpath drainage system.

This system is suitable for Load Class D 400 applications





The ACO MultiDrain™ M100D/M100DS system includes a range of accessories which provide a drainage solution ideal for areas where down pipes from roofs and gutters exit on to the pavement. The ACO Channel Footpath drainage system effectively carries water away from paved areas and across into the adjacent carriageway.

The system uses ACO MultiDrain™ M100D/M100DS shallow depth channels and has two types of kerb outlets and down pipe connectors to suit application requirements.

### Shallow channels

ACO MultiDrain™ MD shallow depth channels are available in two sizes, 75mm and 100mm total depths (ACO M100D / M100DS 075 and ACO M100D / M100DS 0100) and have the option of galvanised or stainless steel edge rails.

### Downpipe connectors

Two down pipe connectors are available to suit channel depth. Manufactured from grey polymer concrete the down pipe connector has a clear opening of Ø75mm and connects to down pipes with outside diameters of up to 82mm.

### Kerb outlets

Two outlets are available to suit the kerb profile of the application, a CFD half battered kerb outlet to suit standard HB kerbs and a CFD Bull nose kerb outlet to match BN kerbs. Manufactured from grey polymer concrete the kerb outlets allow rainwater to discharge into the road gutter from this system.

### Gratings

Traditionally solid ductile iron covers are selected in channel footpath drainage applications but all ACO MultiDrain™ M100D/M100DS gratings are suitable for use with this system. The system's load class rating is determined by the grating selected, further information of gratings within the range can be found on pages 9-14.



23406DL  
Ductile iron solid cover

### ACO MultiDrain™ M100D shallow depth channels with UltraSTEEL™ galvanised edge rails

Product code	Description	Length (mm)	Width overall (mm)	Depth overall (mm)	Invert depth (mm)	Invert Type	Weight (kg)
23075	M100D No. 075	1000	135	75	55	1	9.2
23076	M100D No. 075V	1000	135	75*	55	1	8.85
23110	M100D No. 0100	1000	135	100	80	1	11
23111	M100D No. 0100V	1000	135	100*	80	1	11

### ACO MultiDrain™ M100DS shallow depth channels with stainless steel edge rails

Product code	Description	Length (mm)	Width overall (mm)	Depth overall (mm)	Invert depth (mm)	Invert Type	Weight (kg)
24075	M100DS No. 075	1000	135	75	55	1	10.9
24076	M100DS No. 075V	1000	135	75*	55	1	10.55
24110	M100DS No. 0100	1000	135	100	80	1	12.7
24111	M100DS No. 0100V	1000	135	100*	80	1	12.4

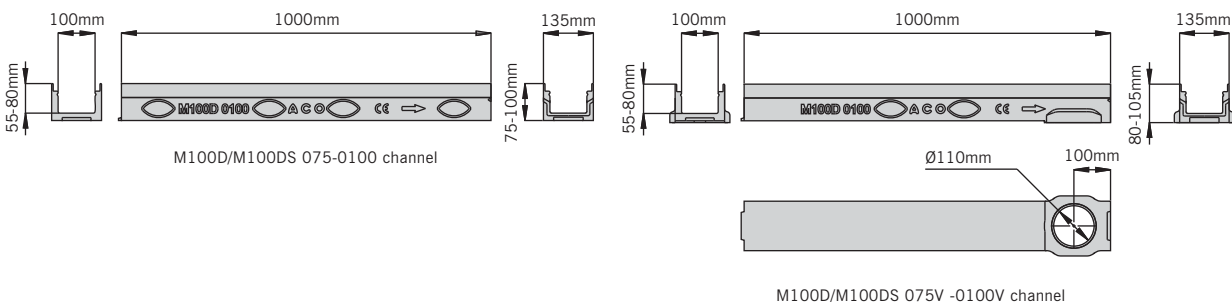

Note: V Indicates channel with cast in triple lipped seals for water tight connection. See page 35 for further details.  
\* 075V and 0100V channels have a depth overall around the outlet of 80mm (075V) and 105 (0100V).



# ACO MultiDrain™ MD System

## Technical Data

### Down pipe connectors

Product code	Description	Length (mm)	Width overall (mm)	Depth overall (mm)	Invert depth (mm)	Invert Type	Weight (kg)
23450	CFD075 downpipe connector grey	150	135	75	n/a	n/a	2.4
23451	CFD0100 downpipe connector grey	150	135	100	n/a	n/a	3

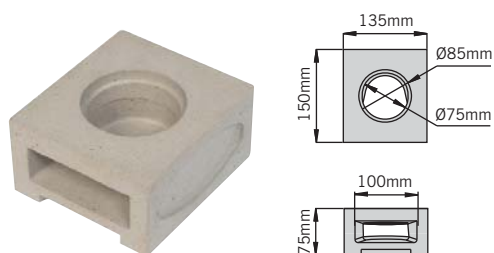

CFD 075 downpipe connector

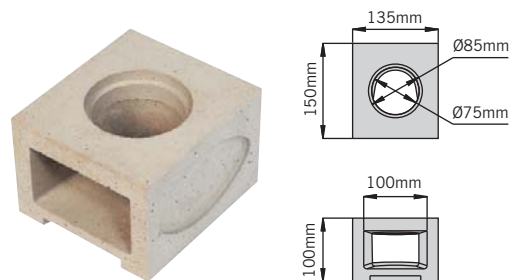

CFD 0100 downpipe connector

### Kerb outlet profiles

Product code	Description	Length (mm)	Width overall (mm)	Depth overall (mm)	Invert depth (mm)	Invert Type	Weight (kg)
23452	CFD kerb outlet half batter grey	125	135	225	n/a	n/a	6.7
23453	CFD kerb outlet bull nose grey	125	135	225	n/a	n/a	6.95

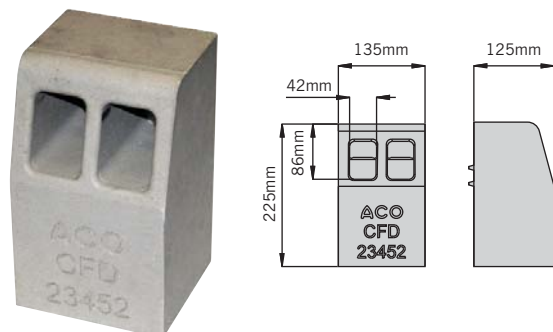

CFD kerb outlet half batter

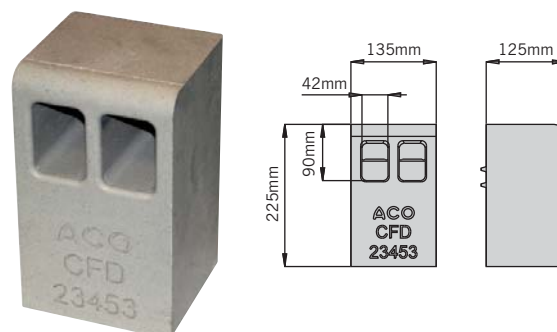

CFD bull-nose kerb outlet



# ACO MultiDrain™ MD Accessories - features, functions and benefits

## Channel base knockout details

All ACO MultiDrain™ MD constant depth channels in the height range 0.0 to 30.0 are supplied with a pre formed knockout detail in the base of the channels. This knockout detail positioned at the male end of the channel allows a vertical connection to be made from the channel to a Ø110mm (100mm wide bore) or Ø160mm (150mm and 200mm wide bore) U-PVC pipe system. The knockout detail on the base of the channel is indicated by a "hammer" symbol. The method of removal and pipe connection is described below.



Knockout detail.

### FUNCTIONS:

**Step 1:** Pre formed knockout detail



**Step 2:** Support channel around knockout detail by placing the channel on sand or soft earth for example. Tap the knockout panel from the side indicated by the Hammer symbol to remove panel.



**Step 3:** Push fit pipe into recess provided and seal as required. For recommended sealants refer to the section headed "watertight sealing".



## Channel side wall connection detail

An additional feature provided on all 500mm long channels are removable side wall panels, which allow channel runs to be connected together to form "T" or "L" junctions for continuous water flow through the system. Where channel connections are to be made to the side wall of these units a female joint detail is provided to aid alignment and fast installation.



Removable side wall panel.

### FUNCTIONS:

**Step 1:** Using a disc cutter as shown, cut a cross into the panel provided. Ensure cuts extend to but not beyond the perimeter recess surrounding the removable panel.



**Step 2:** Tap segments of panel between the cuts to remove the panel.



**Step 3:** Use a chisel to tidy up any remaining material. Channel connection can now be made and sealed as required.



## Shallow Channels

The ACO MultiDrain™ MD shallow channels are available in either 75mm or 100mm overall depths. These units are ideal for use where installation depths are restricted such as in structural slabs, bridge decks and roofs. All units can be sealed for watertight installations as each unit is supplied with a preformed sealant groove (see section headed watertight sealing for further details).

The shallow channels identified with a "V" such as the 075V and 0100V units have a cast-in triple lipped seal in their base for push fit watertight connections to Ø110mm U-PVC pipe. These triple lipped seals are manufactured from SEBS-TPE have excellent chemical, UV and weather resistance.



### FUNCTIONS:

**Step 1:** Ensure Triple lipped seal and pipe spigot are clean and free from debris.



**Step 2:** Lubricate joint faces as required and push fit pipe into the seal. The pipe is fully fitted when the end of the pipe is flush with the internal base of the channel.



# ACO MultiDrain™ MD System

## Technical Data

### Step connector

Each width of MultiDrain™ MD has available a step connector manufactured from polymer concrete. This unit is used between constant depth channel joints where a stepped fall channel installation is required and takes up the 50mm height difference between units. The step connector ensures a smooth water flow within the channel system.



#### FUNCTIONS:

**Step 1:** Place step connector into the base of the deeper channel to be jointed as shown.



**Step 2:** Push channel joint together to lock step connector in place forming a smooth transition between units as shown.



### Watertight sealing

ACO MultiDrain™ MD channels are generally installed without a particular water seal. Once butt jointed and with a concrete surround a fairly watertight installation is achieved. If however a water tight system is required each MultiDrain™ MD channel is provided with a sealant groove allowing the system to be sealed by the application of a flexible sealant either during or following installation. For rainwater applications we recommend a single component, polyurethane based elastomeric joint sealant such as Debussa Masterflex 472 or Sikaflex 11FC or similar.

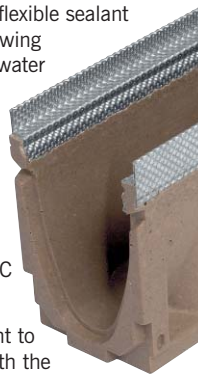

Application of sealant to be in accordance with the sealant manufacturers recommendations, but for guidance a typical method of application is as follows.

#### FUNCTIONS:

**Step 1:** Jointing faces of the channels to be sound and cleaned to remove all loose material, dust, oil and grease. This can be done by the use of a wire brush.



**Step 2:** Butt joint the channels & install as per ACO installation instructions. Ensuring joints are still clean (surfaces can be damp but no water droplets should be evident) apply sealant with a cartridge gun approximately 5mm thick to the end face of the channel & completely fill the sealant groove. Note this type of channel can be sealed either at or following installation.



**Step 3:** Wipe excess sealant from the inside faces of the channel & inspect sealant groove to ensure it has been fully filled with sealant. Leave sealant to cure before use as per the sealant manufactures recommendations.



### Multifunctional endcap

A Multifunctional endcap is provided for each channel width that is designed to be used with all channel heights in each range. Manufactured from polypropylene these versatile endcaps can be adjusted on site to perform the function of a closing endcap or as an inlet/outlet endcap for connection to Ø110mm (100mm wide bore) or Ø160mm (150mm and 200mm wide bore) U-PVC pipe.

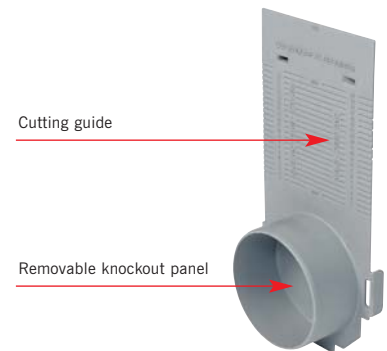

Cutting guide

Removable knockout panel

#### FUNCTIONS:

**Closing endcap:** The end cap supplied fits directly to the deepest channel within the system. All other channel heights can be accommodated by simply cutting the end cap to suit. A cutting guide is printed on the front of the end cap plate. The end cap is fastened to the channel by two clips and can be connected to either male or female channel end.



Adjusting end cap.

Fitting end cap to channel

**Inlet & Outlet end cap:** The end cap has a knockout panel which can be removed with a hammer. Once fitted to the channel the end cap performs either an inlet or outlet function and is designed to provide a connection to Ø110mm (100mm wide bore) or Ø160mm (150mm and 200mm wide bore) U-PVC pipes.



Removing knockout panel

Pipe connection to end cap



## Sump unit

A polymer concrete chamber unit which provides the capacity to hold water and silt, and also provides an outlet for the channel system.

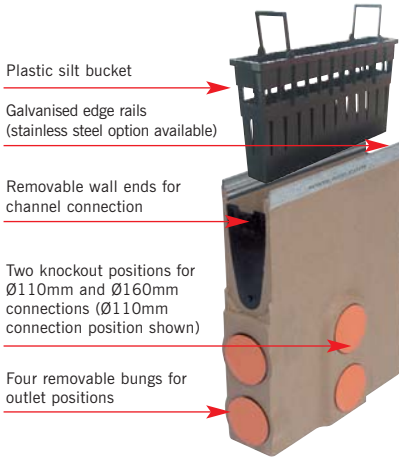

### FUNCTIONS:

**Step 1:** Triple lipped seals for watertight connections



**Step 2:** Unit wall ends can easily be removed using knife or saw



**Step 3:** Two knockouts for Ø110mm and Ø160mm pipe connections. For knockout removal refer to method stated on page 35 headed 'Channel side wall connection detail'.



## Roddable foul air traps

A drain connector available in Ø110mm and Ø160mm for connection to foul or combined drainage. Foul air traps come complete with removable bung for rodding and are manufactured from highly durable recyclable MDPE.



### FUNCTIONS:

**Step 1:** Push the foul air trap into place.



**Step 2:** Bung can be removed for rodding



## ACO Universal gully

A recycled plastic & ductile iron modular system purposely designed for use with ACO channel drainage systems up to 200mm internal width. The system provides a high capacity for retaining water and also an outlet for the drainage system.



### FUNCTIONS:

**Step 1:** Once installed ACO Universal Gully can be cut to match channel depth



**Step 2:** The cut ACO Universal Gully matches the profile of the ACO MultiDrain™ MD channel.



**Note:** Full installation details are available to download from [www.aco.co.uk](http://www.aco.co.uk)

# ACO MultiDrain™ MD System

## Technical Data

### Design method

ACO MultiDrain™ MD channels are available in three widths (100mm, 150mm and 200mm) and each width is available in several depths of constant invert channel. The channels can be in runs of constant invert depth (Type 1) or in a stepped series of invert depths (Type 3). The 100mm wide M100D channel is also available with a pre-sloped invert to form channel runs of 0.5% invert slope at up to 20m length (Type 2). The run lengths of pre-sloped invert can be extended by lengths of constant invert channel.

The channels may be laid with the gratings level. If there is some longitudinal fall, then the hydraulic capacity will be increased, allowing greater spacing between outfalls.

The hydraulic capacity of channels accepting lateral inflow all along their length can be calculated by the analysis of the differential equations for spatially varied flow, a procedure that requires a computer program such as the proprietary ACO Hydro software.

For detailed designs using Hydro, please contact the ACO Design Services team. The team may also be consulted for advice where the inflow is not uniformly distributed along the channel and for channels with pre-sloped inverts.

The tables on the following page have been produced from the ACO Hydro software to facilitate a quick manual design method for the determination of the drainage requirements. The columns of drainage catchment area ( $A \text{ m}^2$ ) are based on a rainfall intensity of 50mm/h, but can be adapted for use at any rainfall intensity. The columns of maximum flow rate ( $Q \text{ l/s}$ ) and maximum lateral inflow ( $q \text{ l/s/m}$ ) can be used at any rainfall intensity. The table of sloping invert channel capacities can be used for the design of M100D sloping invert channels.

### DESIGN EXAMPLE

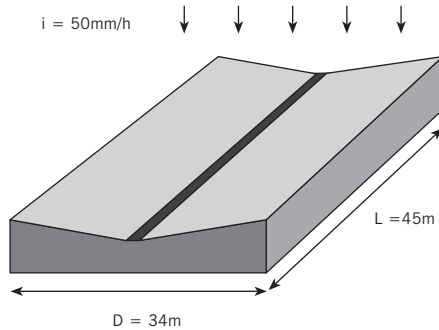

For a design of MultiDrain™ M100D, assume the following figures:

$D = 34\text{m}$  (depth of catchment area)

$L = 45\text{m}$  (length of channel run = length of catchment)

$i = 50\text{mm/h}$  (design rainfall intensity)

Ground slope = 0%

Note that any other rainfall intensity may be used. Typical intensities (from BS EN 752) are 50mm/h for areas where some ponding could be tolerated for a few minutes after heavy rainfall, or 75mm/h where ponding cannot normally be tolerated.

#### 1. Determine the area

$$\text{Area} = L \times D = 45 \times 34 = 1530\text{m}^2$$

For a quick analysis, see the tables and the columns for Area.

1530m<sup>2</sup> is too large for one 45m run of ACO MultiDrain™ M100D

$$\text{Try } 1530 \times 1/2 = 765\text{m}^2$$

$$L \times 1/2 = 23\text{m}$$

Estimating between the rows for 20m and 30m lengths

One 23m run of ACO MultiDrain™ M100D 20.0 can drain approx 800m<sup>2</sup>  
Hence two runs can drain the 1530m<sup>2</sup>

Or for a more detailed analysis, determine the total flow rate, as follows

#### 2. Determine total flow (Q)

$$Q = (\text{Area} \times i) / 3600 = (1530 \times 50) / 3600 = 21.3 \text{ l/s}$$

#### 3. Determine lateral inflow (q)

$$q = Q / L = 21.3 / 45 = 0.473 \text{ l/s/m}$$

#### 4. Determine suitable channel sizes and lengths

For example, would a sump at 1/3 length work with a lateral inflow of 0.473 l/s/m?

1/3 L = 15m, ACO MultiDrain™ MD 10.0 will be adequate

2/3 L = 30m, ACO MultiDrain™ MD 30.0 will be adequate

#### 5. Check Outlet capacity

Ensure that the proposed outlet has sufficient hydraulic capacity by reference to the product technical pages.

#### 6. Solutions

Three options are sketched (right). There are other options, including M100D sloping invert channels or a 45m length run to an outfall using M150D 20.0 channels.

#### Option 1

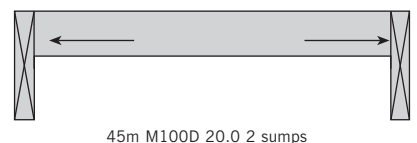

#### Option 2

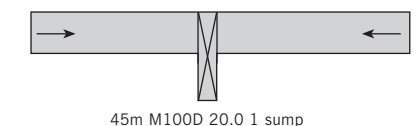

#### Option 3

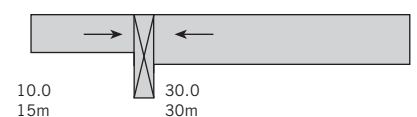

X Denotes sump unit



## Hydraulic Performance Tables (for lateral flow)

### Notes for ACO MultiDrain M100D Hydraulic tables

Maximum capacities for each constant depth channel, assuming uniform lateral inflow to the channel.

Q (l/s) is the maximum total flow that the channel can carry.

q (l/s/m) is the maximum possible lateral inflow.

The maximum possible catchment depth is  $q \div i$ , where  $i$  is the rainfall intensity in l/s/m<sup>2</sup>.

A (m<sup>2</sup>) is the maximum area that can be drained at a rainfall intensity of 50mm/h (0.014 l/s/m<sup>2</sup>).

At other rainfall intensities, the area can be determined by proportion, e.g. at 75mm/h, the maximum area drained will be the tabulated area x 50/75.

### ACO Drain Design Services Team

Please contact the Design Services Team on 01462 816666. for advice on channels with stepped or sloping inverts, channels with non-uniform inflow, or channels receiving point inflows at the end or at intermediate locations.

The Design Services Team will be pleased to assist with any technical queries, scheme designs or parts schedules.

### ACO M100D constant depth channels

M100D 0.0 Overall depth 150mm									
Length to outlet (m)	Slope %								
	0%			0.5%			1%		
	Q (l/s)	q (l/s/m)	A (m <sup>2</sup> )	Q (l/s)	q (l/s/m)	A (m <sup>2</sup> )	Q (l/s)	q (l/s/m)	A (m <sup>2</sup> )
5	5.3	1.05	378	5.3	1.05	378	5.9	1.18	425
10	4.9	0.49	353	5.5	0.55	396	6.6	0.66	475
15	4.8	0.32	346	5.7	0.38	410	7.1	0.47	508
20	4.5	0.23	324	5.9	0.30	425	7.4	0.37	533
25	4.3	0.17	307	6.1	0.24	437	7.8	0.31	558
30	4.2	0.14	302	6.2	0.21	449	8.0	0.27	572
35	4.0	0.12	290	6.3	0.18	454	8.1	0.23	580
40	4.0	0.10	285	6.4	0.16	461	8.2	0.21	590
45	3.8	0.09	275	6.4	0.14	463	8.3	0.19	599
50	3.8	0.08	270	6.5	0.13	468	8.5	0.17	612
55	3.6	0.07	261	6.5	0.12	471	8.5	0.15	612
60	3.6	0.06	261	6.5	0.11	471	8.5	0.14	612

M100D 10.0 Overall depth 200mm									
Length to outlet (m)	Slope %								
	0%			0.5%			1%		
	Q (l/s)	q (l/s/m)	A (m <sup>2</sup> )	Q (l/s)	q (l/s/m)	A (m <sup>2</sup> )	Q (l/s)	q (l/s/m)	A (m <sup>2</sup> )
5	9.0	1.80	648	9.0	1.80	648	10.0	2.00	720
10	8.4	0.84	605	9.4	0.94	677	11.0	1.10	792
15	8.1	0.54	583	9.8	0.65	702	11.6	0.77	832
20	7.7	0.39	554	9.8	0.49	706	12.0	0.60	864
25	7.4	0.30	531	10.0	0.40	720	12.5	0.50	900
30	7.2	0.24	518	10.2	0.34	734	12.6	0.42	907
35	7.0	0.20	504	10.3	0.30	743	13.0	0.37	932
40	6.8	0.17	490	10.4	0.26	749	13.2	0.33	950
45	6.6	0.15	476	10.4	0.23	745	13.5	0.30	972
50	6.5	0.13	468	10.5	0.21	756	13.7	0.27	983
55	6.3	0.11	451	10.6	0.19	764	13.8	0.25	990
60	6.1	0.10	441	10.7	0.18	769	13.8	0.23	994

M100D 20.0 Overall depth 250mm									
Length to outlet (m)	Slope %								
	0%			0.5%			1%		
	Q (l/s)	q (l/s/m)	A (m <sup>2</sup> )	Q (l/s)	q (l/s/m)	A (m <sup>2</sup> )	Q (l/s)	q (l/s/m)	A (m <sup>2</sup> )
5	13.3	2.65	954	13.3	2.65	954	14.6	2.92	1051
10	12.5	1.25	900	13.6	1.36	979	15.8	1.58	1138
15	11.9	0.79	853	14.0	0.93	1004	16.7	1.11	1199
20	11.4	0.57	821	14.2	0.71	1022	17.2	0.86	1238
25	11.0	0.44	792	14.8	0.59	1062	17.5	0.70	1260
30	10.5	0.35	756	14.7	0.49	1058	18.0	0.60	1296
35	10.2	0.29	733	14.7	0.42	1058	18.2	0.52	1310
40	10.0	0.25	720	14.8	0.37	1066	18.4	0.46	1325
45	9.7	0.22	697	14.9	0.33	1069	18.5	0.41	1328
50	9.5	0.19	684	15.0	0.30	1080	19.0	0.38	1368
55	9.4	0.17	673	15.1	0.28	1089	19.2	0.35	1385
60	9.2	0.15	661	15.1	0.25	1089	19.3	0.32	1386

For M100D 30.0 hydraulics tables see next page



# ACO MultiDrain™ MD System

## Technical Data

### ACO M100D constant depth channels

M100D 30.0 Overall depth 300mm									
Length to outlet (m)	Slope %								
	0%			0.5%			1%		
	Q (l/s)	q (l/s/m)	A (m <sup>2</sup> )	Q (l/s)	q (l/s/m)	A (m <sup>2</sup> )	Q (l/s)	q (l/s/m)	A (m <sup>2</sup> )
5	18.4	3.67	1321	18.4	3.67	1321	20.0	4.00	1440
10	17.0	1.70	1224	18.5	1.85	1332	21.0	2.10	1512
15	16.2	1.08	1166	18.8	1.25	1350	21.8	1.45	1566
20	15.6	0.78	1123	19.0	0.95	1368	22.6	1.13	1627
25	15.0	0.60	1080	19.3	0.77	1386	23.3	0.93	1674
30	14.4	0.48	1037	19.2	0.64	1382	23.7	0.79	1706
35	14.0	0.40	1008	19.3	0.55	1386	23.8	0.68	1714
40	13.6	0.34	979	19.3	0.48	1390	24.0	0.60	1728
45	13.1	0.29	946	19.4	0.43	1393	24.3	0.54	1750
50	12.9	0.26	925	19.5	0.39	1404	24.5	0.49	1764
55	12.7	0.23	911	19.8	0.36	1426	24.8	0.45	1782
60	12.3	0.21	886	19.8	0.33	1426	25.2	0.42	1814

### ACO M100D Shallow Depth Channels

M100V 075 Overall depth 75mm									
Length to outlet (m)	Slope %								
	0%			0.5%			1%		
	Q (l/s)	q (l/s/m)	A (m <sup>2</sup> )	Q (l/s)	q (l/s/m)	A (m <sup>2</sup> )	Q (l/s)	q (l/s/m)	A (m <sup>2</sup> )
5	1.3	0.25	91	1.3	0.25	91	1.3	0.25	91
20	1.0	0.05	75	1.3	0.06	91	1.5	0.08	108
40	0.9	0.02	63	1.3	0.03	92	1.9	0.05	137
60	0.8	0.01	56	1.3	0.02	92	1.9	0.03	137

M100D 0100 Overall depth 100mm									
Length to outlet (m)	Slope %								
	0%			0.5%			1%		
	Q (l/s)	q (l/s/m)	A (m <sup>2</sup> )	Q (l/s)	q (l/s/m)	A (m <sup>2</sup> )	Q (l/s)	q (l/s/m)	A (m <sup>2</sup> )
5	2.4	0.48	171	2.4	0.48	171	2.6	0.51	184
20	2.0	0.10	144	2.6	0.13	187	3.4	0.17	242
40	1.7	0.04	124	2.8	0.07	199	3.5	0.09	251
60	1.5	0.03	108	2.8	0.05	203	3.5	0.06	252

### ACO M100D sloping depth channels

Total Flow Rate (litres / sec)				
Length to outlet (m)	Start channel number			
	1	6	11	16
5	6.7	8.6	10.7	12.9
10	7.8	9.7	11.8	
15	8.9	10.9		
20	10.0			

NB Constant invert depth channels can be used to extend the channel length. Please contact ACO Design Services team.

### Notes on table usage

This table may be used for MultiDrain™ M100D sloping invert channels. The table shows capacities for runs outfalling to sumps through units 5, 10, 15 and 20, although any unit can connect to the sump and their capacities can be estimated by interpolation.

It is assumed that the gratings are laid level. Where the run is laid with a longitudinal ground slope, the capacities can be considerably increased, or the length to outfall extended. Please contact ACO Design Services team.





## Notes for ACO MultiDrain M150D Hydraulic tables

Maximum capacities for each constant depth channel, assuming uniform lateral inflow to the channel.

Q (l/s) is the maximum total flow that the channel can carry.

q (l/s/m) is the maximum possible lateral inflow.

The maximum possible catchment depth is  $q_s/i$ , where i is the rainfall intensity in l/s/m<sup>2</sup>.

A (m<sup>2</sup>) is the maximum area that can be drained at a rainfall intensity of 50mm/h (0.014 l/s/m<sup>2</sup>).

At other rainfall intensities, the area can be determined by proportion, e.g. at 75mm/h, the maximum area drained will be the tabulated area x 50/75.

## ACO M150D constant depth channels

M150D 0.0 Overall depth 210mm									
Length to outlet (m)	Slope %								
	0%			0.5%			1%		
	Q (l/s)	q (l/s/m)	A (m <sup>2</sup> )	Q (l/s)	q (l/s/m)	A (m <sup>2</sup> )	Q (l/s)	q (l/s/m)	A (m <sup>2</sup> )
10	13.3	1.33	958	17.4	1.74	1253	20.2	2.02	1454
20	12.4	0.62	896	18.9	0.94	1359	22.9	1.15	1649
30	11.8	0.39	851	19.8	0.66	1423	24.7	0.82	1778
40	11.3	0.28	812	20.5	0.51	1475	25.8	0.65	1858
50	10.8	0.22	778	21.0	0.42	1508	26.6	0.53	1915
60	10.4	0.17	747	21.3	0.36	1534	27.4	0.46	1970
70	10.1	0.14	726	21.6	0.31	1552	27.9	0.40	2006
80	9.7	0.12	697	21.8	0.27	1572	28.3	0.35	2039
90	9.5	0.11	680	22.0	0.24	1581	28.6	0.32	2061
100	9.2	0.09	662	22.1	0.22	1591	29.0	0.29	2088

M150D 10.0 Overall depth 260mm									
Length to outlet (m)	Slope %								
	0%			0.5%			1%		
	Q (l/s)	q (l/s/m)	A (m <sup>2</sup> )	Q (l/s)	q (l/s/m)	A (m <sup>2</sup> )	Q (l/s)	q (l/s/m)	A (m <sup>2</sup> )
10	19.6	1.96	1408	21.5	2.15	1548	24.8	2.48	1786
20	18.3	0.92	1319	23.1	1.15	1662	27.9	1.39	2007
30	17.5	0.58	1259	24.2	0.81	1743	29.8	0.99	2147
40	16.6	0.42	1198	25.0	0.62	1797	31.3	0.78	2255
50	16.1	0.32	1156	25.5	0.51	1836	32.3	0.65	2322
60	15.4	0.26	1110	25.9	0.43	1866	33.2	0.55	2389
70	15.0	0.21	1079	26.2	0.37	1885	33.7	0.48	2429
80	14.6	0.18	1048	26.6	0.33	1912	34.2	0.43	2460
90	14.0	0.16	1011	26.7	0.30	1925	34.6	0.38	2488
100	13.7	0.14	986	26.9	0.27	1937	34.9	0.35	2513

M150D 20.0 Overall depth 310mm									
Length to outlet (m)	Slope %								
	0%			0.5%			1%		
	Q (l/s)	q (l/s/m)	A (m <sup>2</sup> )	Q (l/s)	q (l/s/m)	A (m <sup>2</sup> )	Q (l/s)	q (l/s/m)	A (m <sup>2</sup> )
10	26.6	2.66	1915	29.1	2.91	2095	33.1	3.31	2383
20	25.0	1.25	1800	30.8	1.54	2218	36.6	1.83	2635
30	23.9	0.80	1717	32.0	1.07	2300	39.0	1.30	2808
40	22.8	0.57	1639	33.0	0.82	2373	40.6	1.02	2926
50	22.0	0.44	1580	33.7	0.67	2423	42.0	0.84	3024
60	21.2	0.35	1525	34.0	0.57	2445	42.9	0.72	3089
70	20.4	0.29	1472	34.4	0.49	2480	43.8	0.63	3150
80	19.9	0.25	1434	34.6	0.43	2494	44.3	0.55	3191
90	19.3	0.21	1387	34.9	0.39	2514	44.8	0.50	3227
100	18.8	0.19	1354	35.1	0.35	2527	45.2	0.45	3254

For M150D Shallow channel hydraulics tables see next page



# ACO MultiDrain™ MD System

## Technical Data

### ACO M150D shallow depth channels

M150D 0100 Shallow Channel - Overall depth 100mm									
Length to outlet (m)	Slope %								
	0%			0.5%			1%		
	Q (l/s)	q (l/s/m)	A (m <sup>2</sup> )	Q (l/s)	q (l/s/m)	A (m <sup>2</sup> )	Q (l/s)	q (l/s/m)	A (m <sup>2</sup> )
10	3.8	0.38	274	4.0	0.40	288	5.0	0.50	360
20	3.5	0.17	250	4.4	0.22	317	5.8	0.29	419
30	3.3	0.11	234	4.7	0.16	339	6.6	0.22	475
40	3.1	0.08	222	4.9	0.12	351	7.2	0.18	518
50	2.9	0.06	207	5.0	0.10	360	7.8	0.16	561
60	2.7	0.04	193	5.1	0.08	366	8.2	0.14	590
70	2.6	0.04	184	5.2	0.07	371	8.5	0.12	610
82.1	2.5	0.03	177	5.3	0.06	378	8.7	0.11	628
90	2.4	0.03	175	5.3	0.06	380	8.9	0.10	638
100	2.4	0.02	169	5.3	0.05	382	8.9	0.09	644



## Notes for ACO MultiDrain M200D Hydraulic tables

Maximum capacities for each constant depth channel, assuming uniform lateral inflow to the channel.

Q (l/s) is the maximum total flow that the channel can carry.

q (l/s/m) is the maximum possible lateral inflow.

The maximum possible catchment depth is  $q_{,i}$ , where i is the rainfall intensity in l/s/m<sup>2</sup>.

A (m<sup>2</sup>) is the maximum area that can be drained at a rainfall intensity of 50mm/h (0.014 l/s/m<sup>2</sup>).

At other rainfall intensities, the area can be determined by proportion, e.g. at 75mm/h, the maximum area drained will be the tabulated area x 50/75.

## ACO M200D constant depth channels

M200D 0.0 Overall depth 265mm									
Length to outlet (m)	Slope %								
	0%			0.5%			1%		
	Q (l/s)	q (l/s/m)	A (m <sup>2</sup> )	Q (l/s)	q (l/s/m)	A (m <sup>2</sup> )	Q (l/s)	q (l/s/m)	A (m <sup>2</sup> )
20	25.5	1.27	1835	32.2	1.61	2318	38.9	1.94	2799
40	23.5	0.59	1693	35.4	0.89	2552	44.4	1.11	3197
60	22.1	0.37	1590	37.3	0.62	2687	47.6	0.79	3426
80	21.0	0.26	1515	38.6	0.48	2776	49.8	0.62	3588
100	19.9	0.20	1433	39.3	0.39	2830	51.1	0.51	3679
120	19.1	0.16	1374	40.1	0.33	2886	52.1	0.43	3750
140	18.3	0.13	1320	40.5	0.29	2913	52.6	0.38	3790
160	17.6	0.11	1267	41.0	0.26	2949	52.8	0.33	3802
180	16.7	0.09	1205	41.2	0.23	2968	52.9	0.29	3810
200	16.4	0.08	1181	41.4	0.21	2981	53.0	0.27	3816

M200D 10.0 Overall depth 315mm									
Length to outlet (m)	Slope %								
	0%			0.5%			1%		
	Q (l/s)	q (l/s/m)	A (m <sup>2</sup> )	Q (l/s)	q (l/s/m)	A (m <sup>2</sup> )	Q (l/s)	q (l/s/m)	A (m <sup>2</sup> )
20	34.5	1.73	2485	42.8	2.14	3082	50.9	2.55	3666
40	32.1	0.80	2313	46.6	1.16	3352	58.0	1.45	4176
60	30.2	0.50	2173	49.0	0.82	3529	61.7	1.03	4441
80	28.6	0.36	2062	50.3	0.63	3623	64.3	0.80	4631
100	27.3	0.27	1966	51.3	0.51	3694	66.3	0.66	4774
120	26.0	0.22	1875	52.1	0.43	3750	67.7	0.56	4873
140	24.9	0.18	1794	52.8	0.38	3800	69.0	0.49	4969
160	24.3	0.15	1751	53.3	0.33	3836	69.8	0.44	5023
180	23.4	0.13	1685	53.6	0.30	3862	70.7	0.39	5093
200	22.6	0.11	1627	53.8	0.27	3874	71.4	0.36	5141

M200D 20.0 Overall depth 365mm									
Length to outlet (m)	Slope %								
	0%			0.5%			1%		
	Q (l/s)	q (l/s/m)	A (m <sup>2</sup> )	Q (l/s)	q (l/s/m)	A (m <sup>2</sup> )	Q (l/s)	q (l/s/m)	A (m <sup>2</sup> )
20	44.6	2.23	3213	54.3	2.71	3907	63.7	3.19	4589
40	41.4	1.04	2984	58.6	1.46	4216	71.8	1.79	5167
60	39.1	0.65	2812	61.1	1.02	4398	76.4	1.27	5504
80	37.0	0.46	2667	63.0	0.79	4533	79.6	1.00	5731
100	35.3	0.35	2542	64.3	0.64	4630	81.7	0.82	5882
120	33.8	0.28	2436	65.0	0.54	4683	83.8	0.70	6031
140	32.4	0.23	2330	65.5	0.47	4717	85.1	0.61	6129
160	31.5	0.20	2269	66.1	0.41	4758	86.2	0.54	6209
180	30.4	0.17	2190	66.4	0.37	4782	87.1	0.48	6273
200	29.6	0.15	2131	66.8	0.33	4810	87.8	0.44	6322

For M200D Shallow channel hydraulics tables see next page



# ACO MultiDrain System

## Technical Data

### ACO M200D shallow depth channels

M200D 0100 Shallow Channel - Overall depth 100mm									
Length to outlet (m)	Slope %								
	0%			0.5%			1%		
	Q (l/s)	q (l/s/m)	A (m <sup>2</sup> )	Q (l/s)	q (l/s/m)	A (m <sup>2</sup> )	Q (l/s)	q (l/s/m)	A (m <sup>2</sup> )
20	4.8	0.24	346	6.1	0.31	439	8.0	0.40	576
40	4.2	0.11	302	6.6	0.17	475	9.5	0.24	684
60	3.8	0.06	276	7.0	0.12	505	10.4	0.17	748
80	3.5	0.04	254	7.3	0.09	522	10.9	0.14	786
100	3.3	0.03	238	7.4	0.07	533	11.2	0.11	806
120	3.1	0.03	225	7.4	0.06	536	11.4	0.09	820
140	2.9	0.02	210	7.4	0.05	536	11.6	0.08	835
160	2.8	0.02	200	7.4	0.05	536	11.7	0.07	840
180	2.7	0.01	193	7.4	0.04	536	11.7	0.07	844
200	2.6	0.01	187	7.4	0.04	536	11.7	0.06	844



# Installation details

## CHANNELS WITH TRADITIONAL GRATINGS

### Asphalt Pavement

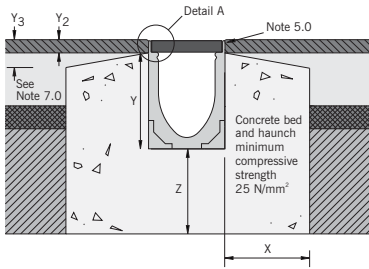

### Concrete Pavement

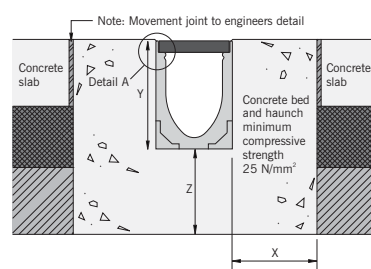

### Block Pavement (option 1 and 2)

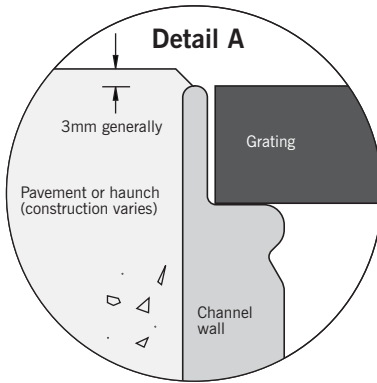
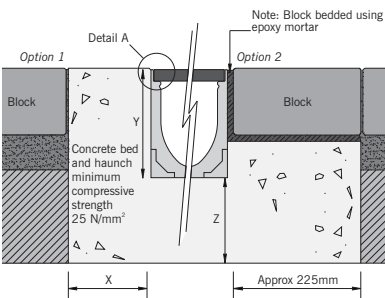

## BRICKSLOT GRATINGS

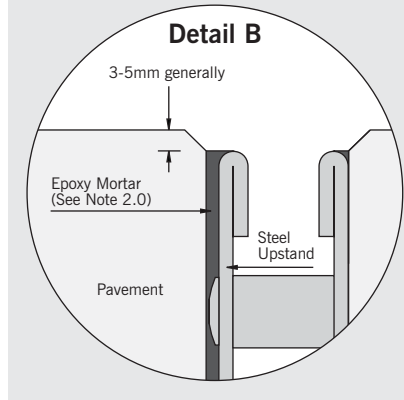
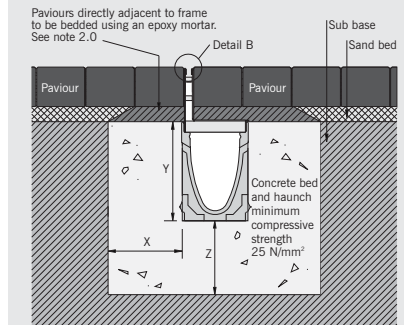

### 1.0 Ground Conditions:

The customer should ensure that the minimum dimensions shown are suitable for the existing ground conditions. Engineering advice may be required.

### 2.0 Block Pavements:

The channels must be supported laterally and therefore blocks must be restrained from movement by bedding securely, e.g. by using an Epoxy or Polymer Modified Mortar for bed and perpendicular joints (for example RONAFIX Mortar Mix C or similar). Engineering advice may be required.

### 3.0 Surface Cracks:

Alternate crack control and movement joints transversely within bed and haunch may reduce unsightly surface cracking. Engineering advice may be required.

### 4.0 Joint Sealant:

Where ACO Drain channel joints and fittings are to be sealed (where used in foul water applications or where impermeability is required, for example) contacting a sealant specialist for guidance on the most appropriate sealing compound to use.

### 5.0 Surface Protection:

In asphalt pavements avoid contact between compaction equipment and channel/grating. This may be achieved by ensuring that the finished surface level lies above the grating level (by at least 3mm). Stones should be removed from grating prior to laying/rolling wearing course.

### 6.0 General Installation Notes:

See ACO drawing E1-E01-003 for general notes on installation. This information is available on request.

### 7.0 Minimum Dimensions of Concrete Surround:

\*e.g. parking areas for all types of road vehicle.  
Not suitable for carriageway of roads or motorways.

\*\*Note dashed line printed on edge rails 35mm below top.

Load Class	A 15	B 125	C 250	D 400*
x	100	150	150	200
y	Full channel height (Less Y2 where necessary)			
Minimum Dimensions (mm)				
z	100	150	150	200
Y2**	35	35	35	35
Maximum Dimensions (mm)				
Y3	100	60	60	60

### 8.0 Grating Security Locks:

All the gratings are held in the channel units by the Drainlock fixing. In addition, gratings type 23405 (Cast Iron) and 12680/12682 (Composite) can be locked in place with an optional security locking kit. See installation drawing E1-E01-040-3.



# ACO MultiDrain™ MD System

## Technical Data

### Chemical resistance chart

ACO Polymer concrete has a high resistance to dilute acids and alkalis, and are unaffected by road salt, fuel and oil, and other commonly encountered chemicals. Further details of the chemical resistance can be obtained from the ACO Design Services team or, for particular chemicals, samples of the polymer concrete can be supplied to customers for their own testing. The chemical resistance will also depend on the temperature of the effluent. Clean water should not exceed 80°C.

The resistance of the gratings and edge rails should also be considered, and stainless steel gratings and edge rails are available in the ACO MultiDrain™ MD system for aesthetically pleasing installations and for specific chemical resistance.

This chemical resistance chart refers to chemicals at ambient temperatures (20°C) and the results are for general guidance only.

Chemical medium	% conc	Resistance: Polyester concrete
Acetic acid, glacial	100	No
Acetic acid	10	Yes
Acetic anhydride	100	No
Acetone	10	No
Acetone	100	No
Alum	100	Yes
Aluminium sulphate	100	Yes
Ammonium chloride	100	Yes
Ammonium nitrate	100	Yes
Ammonium phosphate	65	Yes
Ammonium sulphate	100	Yes
Aniline (aminobenzene)	100	No
Barium chloride	100	Yes
Benzaldehyde	100	No
Benzene	100	No
Benzyl alcohol	100	Yes
Benzyl chloride	100	No
Borax	100	Yes
Boric acid	100	Yes
Bromine	100	No
Bromine water	Saturated	No
Butyl acetate	100	No
Butyric acid	100	Yes
Calcium carbonate	100	Yes
Calcium chloride	100	Yes
Calcium chlorate	8	Yes
Calcium hydroxide	100	Yes
Calcium nitrate	100	Yes
Carbon disulphide	100	No
Carbon tetrachloride	100	Yes
Castor oil	100	Yes
Chlorine gas, wet	100	No
Chlorine water	Saturated	No
Chlorobenzene	100	Yes
Chloroform (trichloro-methane)	100	No
Chromic acid	12	Yes
Citric acid	100	Yes
Copper chloride	100	Yes
Copper nitrate	100	Yes
Cyclohexane	100	Yes
Diesel fuel (DERV)	100	Yes
Dimethyl formamide	100	No
Dimethyl phthalate	100	Yes
Diethyl phthalate	100	Yes
Ethanol	95	No
Ethanolamine	100	Yes
Ethyl acetate	100	No
Ethylene glycol	100	Yes
Ferrous chloride	100	Yes
Ferric chloride	100	Yes
Ferrous sulphate	100	Yes
Formaldehyde	30	Yes
Formic acid	10	Yes
Formic acid	100	No
Fuel oil	100	Yes
Gasoline	100	Yes
Glycerine	100	Yes
Hydrazine	50	No

Chemical medium	% conc	Resistance: Polyester concrete
Hydrobromic acid	48	Yes
Hydrochloric acid	10	Yes
Hydrofluoric acid	10	No
Hydrogen peroxide	30	Yes
Lactic acid	100	Yes
Lead acetate	100	Yes
Magnesium chloride	100	Yes
Magnesium sulphate	100	Yes
Maleic acid	100	Yes
Methyl ethyl ketone (MEK)	100	No
Motor oil	100	Yes
Nickel chloride	100	Yes
Nickel sulphate	100	Yes
Nitric acid	5	No
Nitrobenzene	100	No
Oleic acid	100	Yes
Oxalic acid	100	Yes
Perchloric acid	10	Yes
Perchloroethylene	100	Yes
Phosphoric acid	20	Yes
Phosphorus trichloride	100	No
Potassium carbonate	50	Yes
Potassium chloride	100	Yes
Potassium dichromate	100	Yes
Potassium hydroxide	10	Yes
Potassium nitrate	100	Yes
Potassium permanganate	10	No
Potassium sulphate	100	Yes
Pyridine	100	No
Sodium acetate	100	Yes
Sodium bromide	100	Yes
Sodium carbonate	35	Yes
Sodium chlorate	100	Yes
Sodium chloride	100	Yes
Sodium hydroxide (caustic soda)	50	No
Sodium hypochlorite	18	No
Sodium nitrate	100	Yes
Sodium nitrite	100	Yes
Sodium phosphate	10	Yes
Sodium sulphate	100	Yes
Sodium sulphide	100	Yes
Sodium sulphite	100	Yes
Sodium thiosulphate	100	Yes
Stearic acid	100	Yes
Styrene	100	No
Sulphuric acid	75	No
Sulphuric acid	50	Yes
Sulphuric acid at up to 40°C	10	Yes
Tetachloroethylene	100	Yes
Thioglycolic acid	80	Yes
Thionyl chloride	100	No
Toluene	100	Yes
Toluene sulphonic acid (aqueous solution)	Saturated	Yes
Trichloroacetic acid	50	Yes
Turpentine	100	Yes
Water	100	Yes
Xylene	100	Yes
Zinc sulphate	100	Yes



## Specification clause

The surface drainage system shall be ACO MultiDrain™ (Insert channel description as appropriate e.g. ACO M100D) channel system as supplied by ACO Technologies plc; all materials and components within the scope of this channel system shall be obtained from this manufacturer. The system shall be CE marked and fully compliant with BS EN 1433:2002, certificated to Load Class ( \* ) as defined in BS EN 1433:2002.

A Declaration of Conformity shall be supplied to the Supervising Officer upon request. The system shall be of (100mm†, 150mm†, 200mm†) nominal internal width, manufactured in polyester resin concrete with cast-in (galvanised/stainless†) steel edge rails. The channels shall be installed with manufacturer's grating appropriate to the specified Load Class and locked securely in place using the manufacturer's Drainlock® boltless locking system.

The system shall be installed in accordance with the manufacturer's printed instructions, and the work carried out as specified in drawing no. (... ..) and in accordance with recognised good practice. Standards of workmanship shall generally be as specified in BS EN 752 and BS 8000:Part 14:1989.

† delete non-appropriate information

\* insert information C 250 or D 400 as appropriate

**Note: A specification in NBS format is available to download from [www.thenbs.com](http://www.thenbs.com) or [www.aco.co.uk](http://www.aco.co.uk)**

## Recycled content

ACO Technologies aim to incorporate as much recycled material or waste material as is practicable in their manufactured products. Typically, cast iron materials contain 40% to 90 % recycled iron, and steel products contain 25% to 33% % recycled steel. The total recycled content of each product in the ACO MultiDrain™ MD system will vary as the proportion of the different materials (in channels, edge rails, gratings etc) varies. As an example, ACO MultiDrain™ MD channels with Heelguard™ ductile iron gratings will contain approximately 22% by weight recycled material.

The ACO MultiDrain™ MD products are themselves intended for a long life with low maintenance, to reduce the need to recycle, but when eventually they are no longer needed, much of their content can be readily recycled with a very low risk of pollution to the environment.

## NBS Specifications

ACO MultiDrain™ MD should be specified in section Q10:180. Assistance in completing this clause can be found in the ACO Drain entry in NBS Plus, or please contact the ACO Drain Design Services Team.

## CE Conformity

The ACO MultiDrain™ MD System is fully certified and CE Marked to BS EN 1433:2002.

Test certificates and a declaration of conformity are available on request, please contact ACO Drain Design Services Team on 01462 816666 for further information.



**Note: As with all pre-cast products, polymer concrete units are subject to weight and dimensional tolerances.**



## ACO Technologies plc

- ACO Drain
- ACO Build
- ACO Building Drainage
- ACO Technic
- ACO Sport
- ACO Wildlife

### ACO Drain

A division of ACO Technologies plc  
ACO Business Park,  
Hitchin Road,  
Shefford,  
Bedfordshire  
SG17 5TE

Tel: 01462 816666

Fax: 01462 815895

e-mail Sales: customersupport@aco.co.uk

e-mail Technical: draintechical@aco.co.uk

website: www.aco.co.uk

**The ACO Group: A strong family you can depend on.**

© March 2009 ACO Technologies plc. All reasonable care has been taken in compiling the information in this document. All recommendations and suggestions on the use of ACO products are made without guarantee since the conditions of use are beyond the control of the Company. It is the customer's responsibility to ensure that each product is fit for its intended purpose, and that the actual conditions of use are suitable. This brochure and any advice is provided by ACO Technologies plc (the Company) free of charge and accordingly on terms that no liability including liability for negligence will attach to the Company or its servants or agents arising out of or in connection with or in relation to this brochure or any such advice. Any goods supplied by the Company will be supplied solely upon its standard conditions of sale, copies of which are available on request. The Company's policy of continuous product development and improvement renders specifications liable to modification. Information provided in this brochure is therefore subject to change without prior notification.

#### ACO CARES ABOUT THE ENVIRONMENT

Printed on material approved by the Pan European Forest Certification (PEFC) who provide a means of assuring that products come from sustainably managed forests.



ISO 9001  
FM 13502

