



**Décor**



DC478 Classic Aquamarine

# When it's all about the floor...

**Amtico Décor is an artisan collection, evocative of timeless British designs, perfect for adding decorative detail to a space.**

From the timeless geometry of Classic to the graphic styling of Echo, these floors are at home in both period schemes and modern, contemporary settings. Use Décor for bar skirts, boutique lobbies, elegant bathrooms or anywhere that requires visual impact.



DC485 Chequer Mono with 9mm bronze stripping.

## Creative & flexible

Amtico Décor is created in-house using products from the Amtico Signature collection. This means you have over 200 complementary products available to use alongside your Décor design. Match the Décor palette to create a balanced scheme or go for contrasting materials like wood or stone to create a standout feature.

## Precision-cut detail

Each tile is individually cut and bevelled and comes in a pre-taped module, for quick, clean, easy installation. And made to the same specification as our premium Signature LVT, the finished floor will stand up to heavy footfall and repeated cleaning cycles without losing impact.



20YR COMMERCIAL WARRANTY

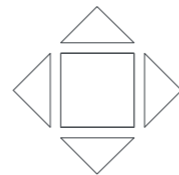

PRECISION-CUT PIECES



DC479 Classic Goldstone with Graphite Slate Stripping, York Oak - Stripwood



DC473 Victorian Star Large York

## A perfect pairing

Amtico is proud to launch its first ever collaboration with Europe's largest conservation charity, the National Trust. Captivated by nature's organic beauty, passionate about the finer details, and unequivocally British, this is a curated collection of three decorative designs in a range of sumptuous colours, all selected from Amtico's premium Signature collection.

Amtico Décor ×  National Trust



# Victorian Star Large

Victorian Star Large follows the same geometry of the its smaller counterpart, but in two classic Oak designs from the Signature collection. Reflecting historic marquetry techniques, the intricate shapes emphasise the natural woodgrains and bring elegant luxury to any space.

1

Pattern

2

Colourways

Layout Illustration

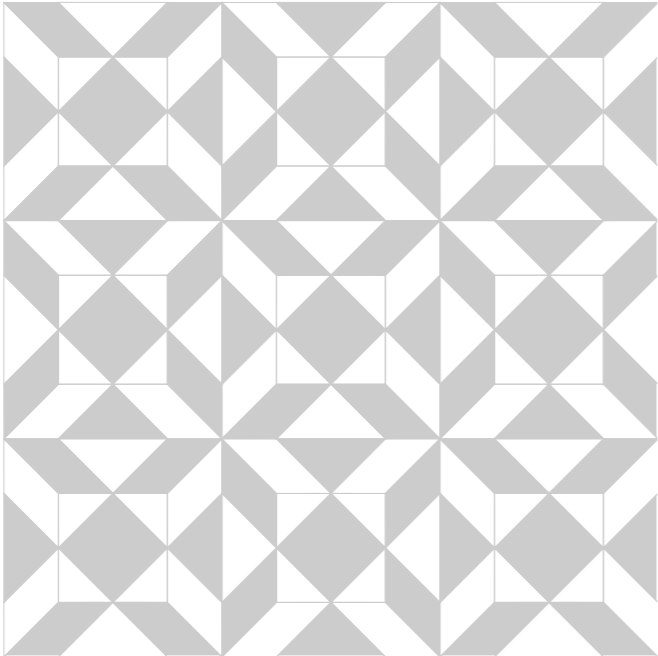

Assembled Tile

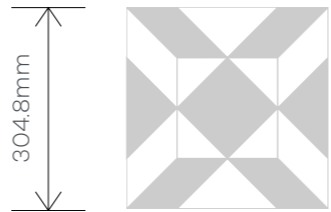
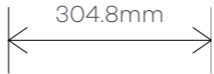

Amtico Décor ×  National Trust



**Victorian Star Large  
Canterbury DC472**

The directional grain in this rich oak brings movement and drama, and echoes of a well-loved hardwood floor.

**Shown here**  
Brushed Oak



**Victorian Star Large  
York DC473**

The soft, golden tones of classic York Oak work beautifully in this elegant pattern, inspired by traditional marquetry.

**Shown here**  
York Oak



# Victorian Star Small

Reminiscent of highly pigmented Victorian floor tiles, this pattern uses precision cutting techniques to create an intricate star pattern. From bold warm reds to luxurious monochrome, Victorian Star Small is created using colours from our Signature collection, giving you a choice of over 200 additional products to use in your scheme.

1

Pattern

4

Colourways

Layout Illustration

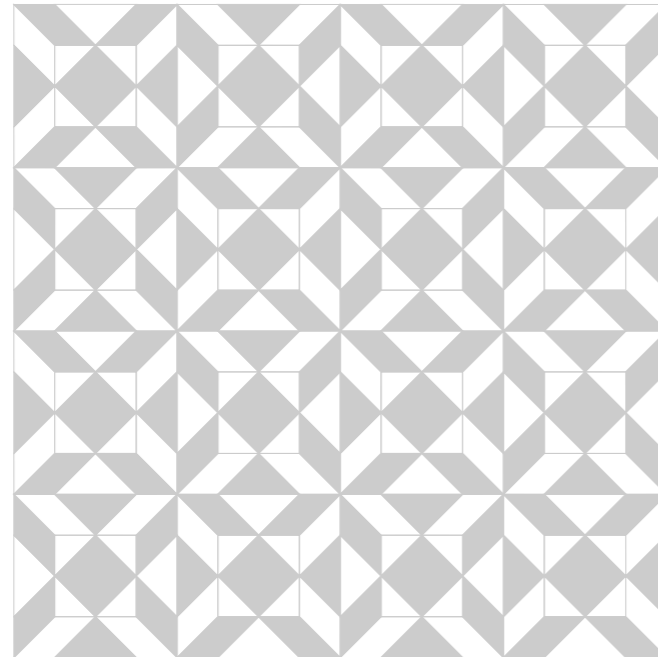

Assembled Tile

228.6mm

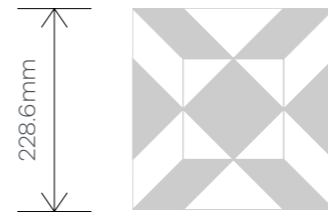

Amtico Décor ×  National Trust



DC469 Victorian Star Small Clarence with Bevelled Diamond Border

▶  
**Victorian Star Small  
 Edison DC468**

A bold combination of warm terracotta with cool, pebble grey brings this intricate pattern to life.

**Shown here**  
 Stucco Clay  
 Stucco Quartz  
 Encaustic Jasper  
 Stucco Putty



▶  
**Victorian Star Small  
 Chester DC470**

Unique and understated, Chester's neutral base with a hint of soft blue is a contemporary take on this traditional geometry.

**Shown here**  
 Stucco Quartz  
 Modernist Lintel  
 Diffusion Charcoal

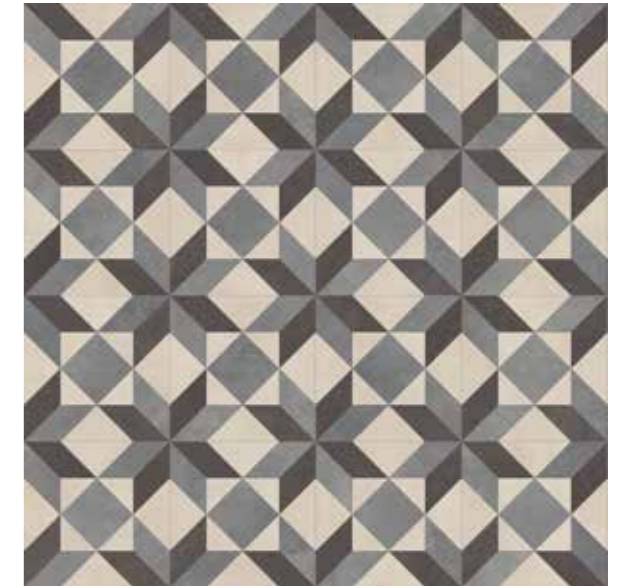

◀  
**Victorian Star Small  
 Clarence DC469**

The high contrast combination of blue tones creates an impactful design, reminiscent of decorative ceramics.

**Shown here**  
 Stucco Flax  
 Stucco Indigo  
 Stucco Quartz



◀  
**Victorian Star Small  
 Otto DC471**

The addition of marble brings a luxurious feel to the sharp, clean lines of this elegant floor.

**Shown here**  
 Graphite Slate  
 Onyx Marble





# Octagon Key

Inspired by the Georgian era, this small scale pattern with its octagon shaped tiles is a decorative take on the classic key stone aesthetic. It's available in four highly useable stone colorways using the Colour Edit palette and luxurious marble from the Signature collection.

1

Pattern

4

Colourways

Layout Illustration

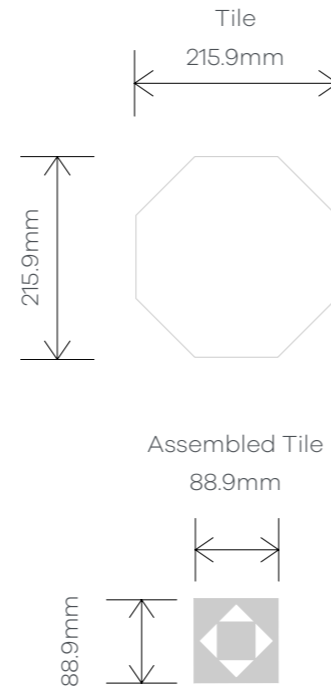
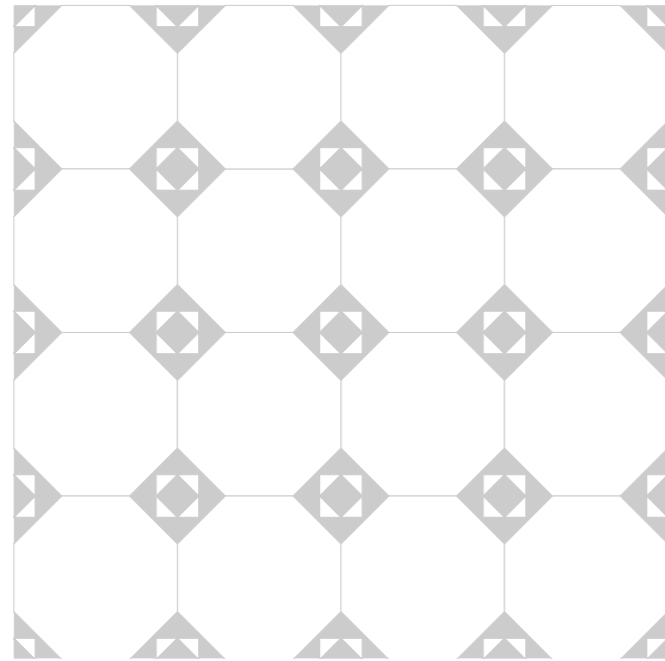

Amtico Décor ×  National Trust



DC477 Octagon Key Rayne



▶  
**Octagon Key Grace DC474**

The soft, tonal greys in this palette create a perfect backdrop for cosy spaces.

**Shown here**

Stucco Quartz  
Stucco Putty  
Stucco Pebble



▶  
**Octagon Key Alma DC476**

A highly useable palette of elegant flax blue and cool cream bringing neutral sophistication to a scheme.

**Shown here**

Stucco Quartz  
Stucco Flax



◀  
**Octagon Key Briar DC475**

Cool blue and dramatic charcoal give this classic key stone design a bold, contemporary feel.

**Shown here**

Stucco Quartz  
Modernist Lintel  
Diffusion Charcoal



◀  
**Octagon Key Rayne DC477**

A high-contrast, luxurious take on a classic design with charcoal slate and creamy marble.

**Shown here**

Graphite Slate  
Onyx Marble





# Classic

From bold black and white to complementary colour combinations, Classic's kaleidoscope shapes create elegant floors with a modern take on an enduring pattern.

1

Pattern

5

Colourways

Layout Illustration

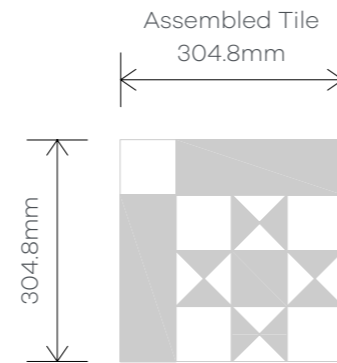
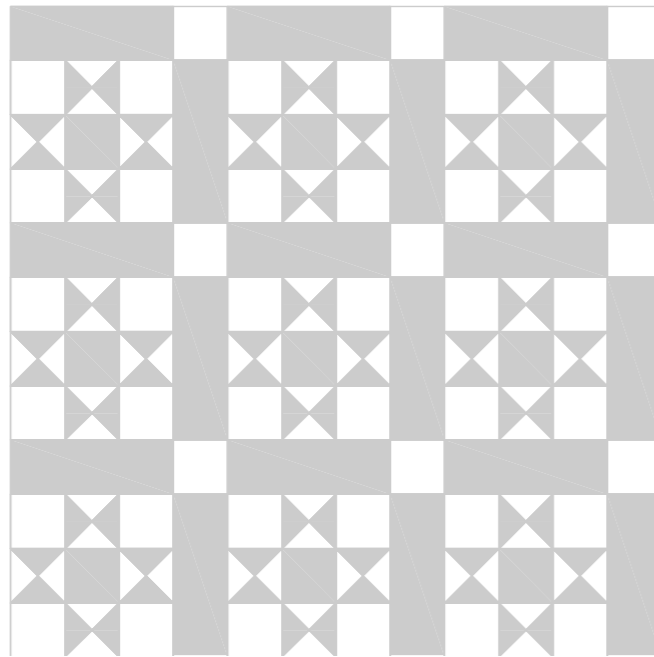

One module equals one assembled tile  
Module size: 304.8mm x 304.8mm supplied in taped modules  
Each tile is individually cut and bevelled



DC257 Classic Mono with Bevelled Diamond Border, Rotterdam Oak - Stripwood

▶  
**Classic Mono DC257**

This striking and elegant monochrome design will make a bold statement. The traditional pairing of grey slate and white makes a stylish entrance when used in a hallway.

**Shown here**  
Pure Plain White  
Graphite Slate

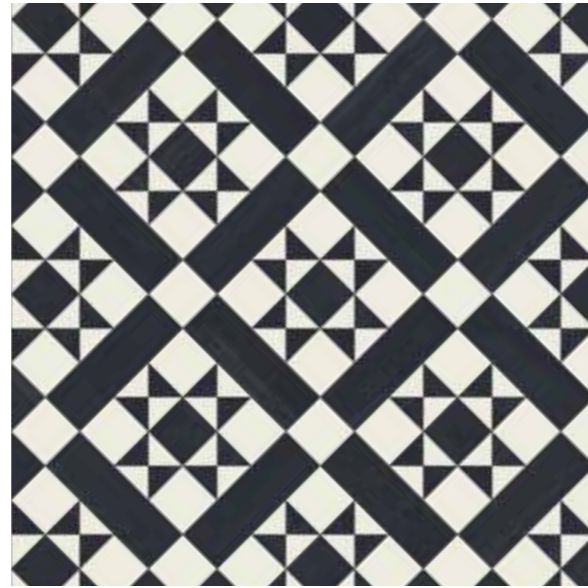

▶  
**Classic Aquamarine DC478**

Think stone, sea and sky - a muted palette that brings harmony to a space. This accessible design will work alone or alongside a complementary product.

**Shown here**  
Stucco Flax, Diffusion Chambray,  
Diffusion Charcoal, Stucco  
Quartz & Stucco Putty



◀  
**Classic Moderna DC313**

The ultimate black and white pattern, made with pure colour for a clean, bold and detailed floor design.

**Shown here**  
Pure Plain White  
Pure Plain Black



◀  
**Classic Goldstone DC479**

Four earthy tones interrupted by a burst of blue. This versatile flooring works equally well as a complete floor or a standout feature, and perfectly suits a traditional scheme.

**Shown here**  
Diffusion Chambray, Stucco  
Quartz, Graphite Slate, Stucco  
Clay & Encaustic Jasper

▶  
**Classic Argent DC294**

Our striking design epitomises classic beauty when in this marble and metallic grey stone combination.

**Shown here**  
Onyx Marble, Stria Volcanic & Kura Caraway



◀  
**Marble Diamond Border DC296B**  
**Marble Diamond Corner DC296C**

Designed specifically for Classic Argent, this border perfectly complements the design to create maximum impact.

**Shown here**  
Onyx Marble, Stria Volcanic & Kura Caraway



“Taking influence from decorative time periods in history, the Décor collection nods to traditional geometry, historic colour reference and authentic texture qualities, emulating the look and feel of decorative, antique floors.”

**Sarah Escott**  
Design Manager



DC294 Classic Argent



# Geo

Inspired by traditional tiled spaces of the Victorian era, Geo's simple square geometry makes a stylish impact in modest spaces. Made using products from the Amtico Signature collection, Geo also works brilliantly as a rug feature in a complementary field.

1

Pattern

4

Colourways

Layout Illustration

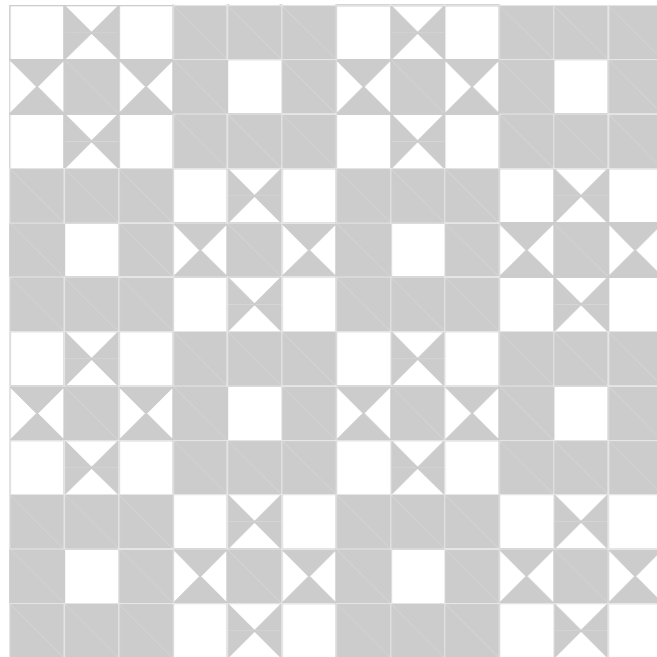

Assembled Tile A

228.6mm

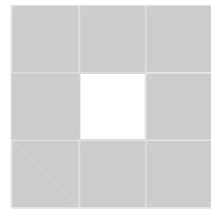

Assembled Tile B

228.6mm

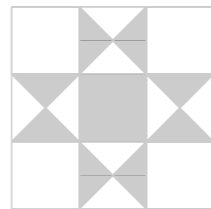

One module equals one assembled tile A and one assembled tile B  
Module size: 228.6mm x 457.2mm supplied in taped modules  
Each tile is individually cut and bevelled



DC481 Geo Poplin with Pinstripe Medium Border with Mitered Corner

▶  
**Geo Melrose DC480**

The exquisite stone tones of Stucco Putty against Stucco Quartz are reminiscent of the natural world.

**Shown here**  
Stucco Putty  
Stucco Quartz



▶  
**Geo Mono DC482**

Deep grey-black tones underpin this more dramatic version of Geo, created with a natural feeling Graphite Slate base and Pure Plain White highlights.

**Shown here**  
Graphite Slate  
Pure Plain White



◀  
**Geo Poplin DC481**

Two neutral shades of Signature's Stucco palette add warm and gentle earthy tones to this geometric pattern.

**Shown here**  
Stucco Pebble  
Stucco Quartz



◀  
**Geo Adelphi DC483**

A muted pop of colour and a cool cream combine to create a soft, inviting update to this traditional tile design.

**Shown here**  
Diffusion Chambray  
Stucco Quartz





# Echo

Echoing the design of encaustic and cement tiles, this simple combination of two colours creates a contemporary look which works as a full floor or as an impactful feature in modern commercial schemes.

**1**      **4**  
Pattern      Colourways

Layout Illustration

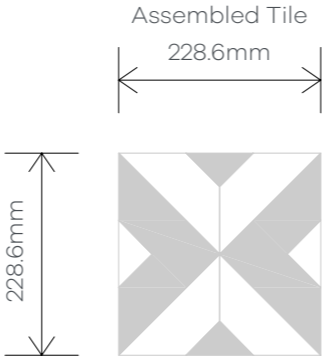
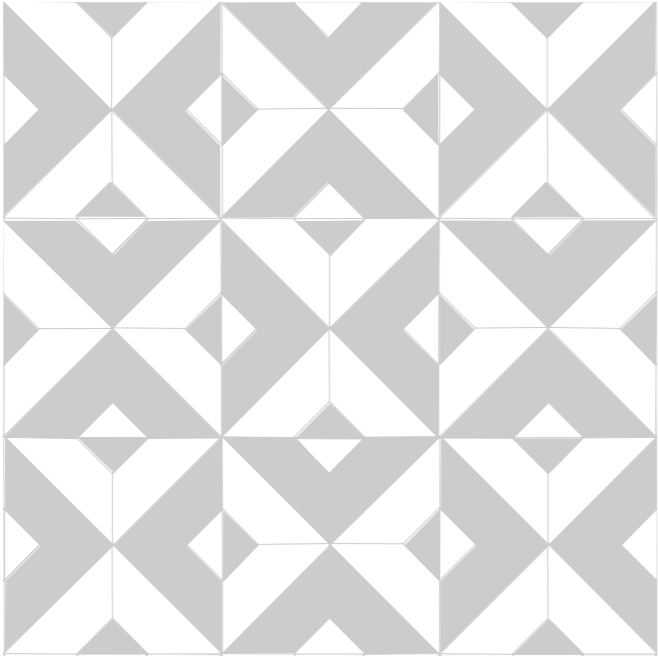

One module equals one assembled tile  
Module size: 228.6mm x 228.6mm supplied in taped modules  
Each tile is individually cut and bevelled



DC456 Echo Keys

▶  
**Echo Ink DC455**

Deep grey-blue and cream combine to offer a sophisticated twist on more conventional black and white ceramics.

**Shown here**  
Stucco Flax  
Stucco Quartz

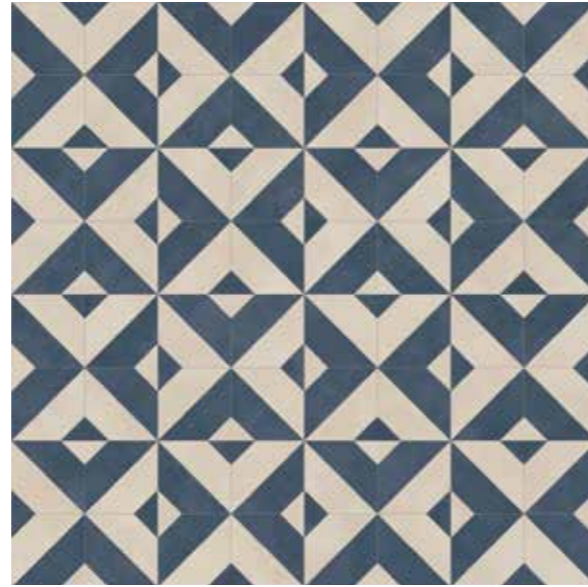

▶  
**Echo Shadow DC457**

Obscure the angular intricacy of Echo by blending two shadowy complementary greys, for a soft yet contemporary design.

**Shown here**  
Modernist Lintel  
Modernist Spire

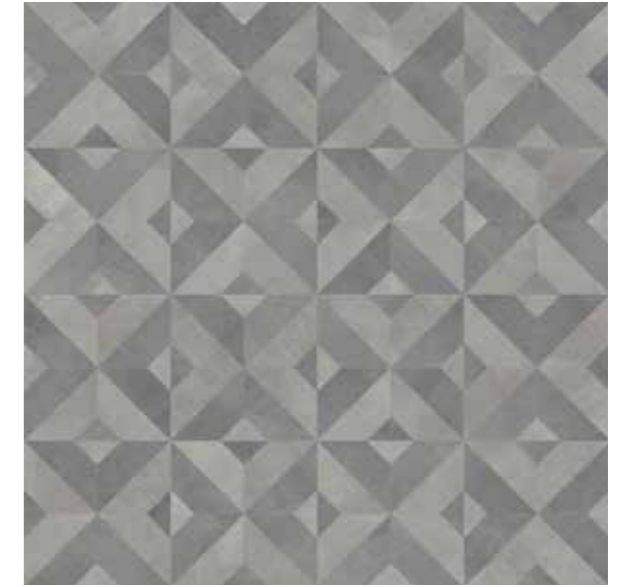

◀  
**Echo Keys DC456**

Striking yet simple - contrast rich charcoal with fresh marble for a dramatic geometric statement.

**Shown here**  
Graphite Slate  
Onyx Marble



◀  
**Echo Ware DC458**

Neutral earthy tones combine and contrast to perfectly demonstrate how this graphic, symmetrical design can work in more traditional schemes.

**Shown here**  
Stucco Clay  
Stucco Quartz





# Chequer

This mini masterpiece comes in two perfectly balanced colour combinations, evocative of traditional tiled hallways. Finish with the new Pinstripe border for an impactful feature.

1

Pattern

2

Colourways

Layout Illustration

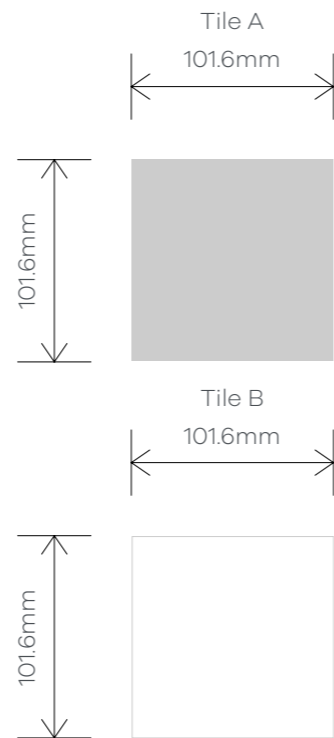
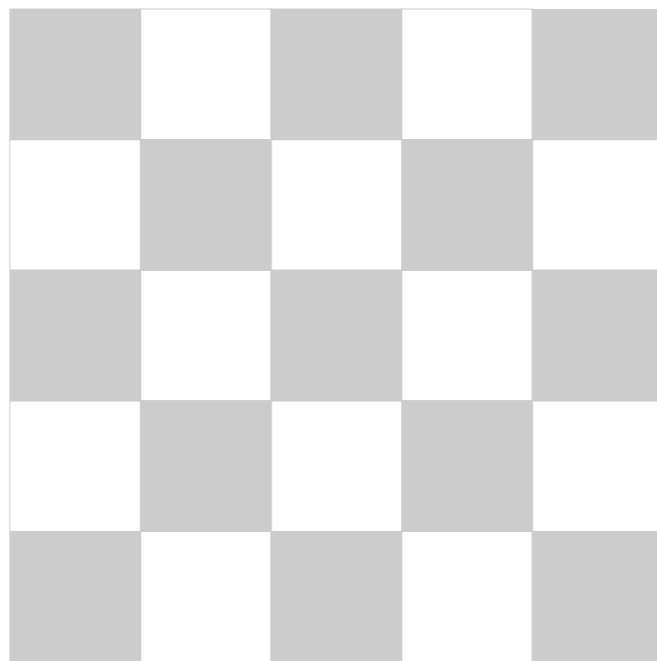

## Chequer Queenside DC484

Sleek, deep grey Graphite Slate is offset by the rich terracotta of Encaustic Jasper for a bold, traditional look.

**Shown here**  
Graphite Slate  
Encaustic Jasper



## Chequer Mono DC485

Dark, charcoal grey and brilliant white provide beautiful contrast in this sleek and contemporary colour scheme.

**Shown here**  
Graphite Slate  
Pure Plain White

# Introducing Décor borders and corners

Choosing the right border has the power to transform a space. Useful for subtly zoning areas, drawing attention to an architectural focal point, or elegantly joining different flooring between rooms, borders undoubtedly elevate a room's aesthetic.

## Bevelled Diamond

Border AROB270B and  
Corner AROC27SB - 76 x 914mm

Products shown: A = Stucco Flax,  
B = Stucco Quartz, C = Stucco Flax

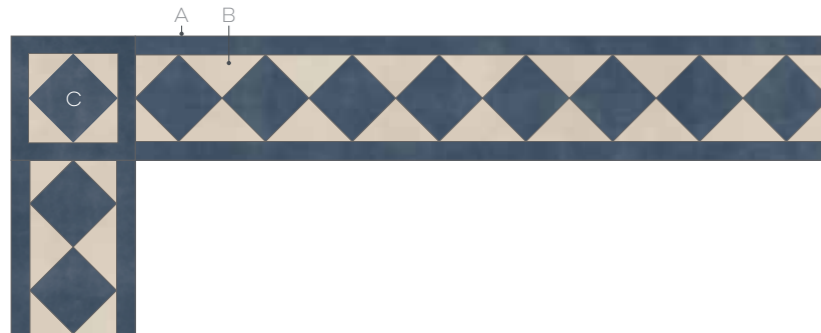

"Borders are the perfect finishing touch for your space. When combined with a complementary perimeter product, they are a fantastic way of framing your interior, and they can be used to dial up or down the level of decoration desired."

## Lorna Williams

Head of Product Design  
and Visual Creation



## Diamond Bevelled Border

All Décor patterns work proportionally with the existing Diamond Bevelled Border pictured here.



DC469 Victorian Star Small with Bevelled Diamond Border

# Designing with Borders

Our simplified pinstripe border designs, enable the floors to be finished with neat proportions and offer either a classic or contemporary feel to a space. Using products from Signature's Colour Edit palette means we have reduced the need for specific Décor borders and opening up the endless design possibilities.



DC478 Classic Aquamarine with Pinstripe Medium Border

Details of all our borders options can be found at [amtico.com](https://www.amtico.com)

## Pinstripe Bold

Border AR0B4000 - 89 x 914mm  
 Products shown: A = Stucco Quartz,  
 B = Diffusion Charcoal, C = Diffusion Charcoal

### Pinstripe Bold with Feature Corner AROC4002



### Pinstripe Bold with Mitred Corner



### Pinstripe Bold with Square Corner AROC4001



## Pinstripe Fine

Border AR0B4001 - 89 x 914mm  
 Products shown: A = Onyx Marble,  
 B = Graphite Slate, C = Graphite Slate

### Pinstripe Fine with Feature Corner AROC4002



### Pinstripe Fine with Mitred Corner



## Pinstripe Medium

Border AR0B4002 - 89 x 914mm  
 Products shown: A = Stucco Flax,  
 B = Stucco Quartz, C = Strucco Quartz

### Pinstripe Medium with Feature Corner AROC4002



### Pinstripe Medium with Mitred Corner



# Installation

Beautiful high-performance Décor floors feature a superior 1mm wear layer and Quantum Guard Elite urethane coating for exceptional durability. Individually cut and bevelled tiles are made to order in the UK by our highly skilled manufacturing team, arriving in pre-assembled and taped modules or individual precision cut pieces for quick and easy installation.\* For details on our technical specification, please visit [amtico.com](http://amtico.com).

For best results, we recommend laying Décor in feature areas of 25m<sup>2</sup> or less. Visit [amtico.com](http://amtico.com) for more information.

\*Individual precision cut pieces relate to Chequer and Octagon Key designs



**amtico**  
flooring

**Amtico UK & European Sales**

Solar Park Southside  
Solihull, West Midlands  
B90 4SH, UK  
+44 (0) 121 745 0800  
[samples@amtico.com](mailto:samples@amtico.com)

**Amtico Head Office**

Kingfield Road  
Coventry  
CV6 5AA, UK  
+44 (0) 24 7686 1400  
[samples@amtico.com](mailto:samples@amtico.com)

**Amtico International Germany**

Im Taubental 11  
41468 Neuss, Germany  
+49 (0) 2131 359 16 0  
[info@amtico.de](mailto:info@amtico.de)

**Amtico International France**

36 Avenue Hoche  
75008 Paris, France  
+33 (0) 1 55 38 95 70  
[info@amtico.fr](mailto:info@amtico.fr)

**Amtico International Scandinavia**

Isafjordsgatan 22  
164 40 Kista, Sweden  
+46 (0) 8 584 233 24  
[info@amtico.se](mailto:info@amtico.se)

**Amtico International HK Ltd**

Rm 2003  
20/F OfficePlus @ Wan Chai  
303 Hennessy Rd, Hong Kong  
+852 2327 7703  
[samples@amtico.com](mailto:samples@amtico.com)

**Amtico International Middle East, Africa & India**

8th Floor  
Building Number 2  
J&G DMCC, Dubai, UAE  
+971 (0) 50 192 33 46  
[samples@amtico.com](mailto:samples@amtico.com)

**Amtico International Australia & New Zealand**

PO Box 752  
Jimboomba  
QLD 4280, Australia  
+61 (0) 477708418  
[australia.orders@amtico.com](mailto:australia.orders@amtico.com)

Visit [amtico.com](http://amtico.com) for more information on our product range, inspiring ideas, maintenance and installation advice. Every effort is made to achieve accurate reproduction of products in this brochure, however printing limitations can be misleading. Selection of products should be made from actual sample. Samples are small pieces cut from standard tiles. They give only a general indication of the design. Tone and shading can vary slightly from batch to batch and it is not possible to guarantee that the sample will exactly match the material supplied. The policy of the Company is one of continuous development and improvement and the right is reserved to add or delete from the range or change patterns without prior notification. All metric sizes are rounded. All products are manufactured in line with EN ISO 10582 and EN1307. Brochure correct at the time of printing.

**amtico**  
signature

**amtico**  
flooring

MLIT.BRU.RB.DEC